

Chapter 2: Vorticity

Circulation and vorticity

Circulation:

$$\Gamma = \oint_C \mathbf{v} \cdot d\mathbf{l}$$

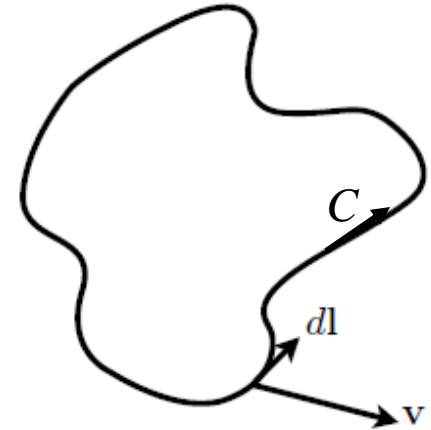

Vorticity:

$$\zeta = \nabla \times \mathbf{v}$$

The vorticity vector is numerically twice the angular speed of rotation of the fluid element about its own axis.

Circulation and vorticity

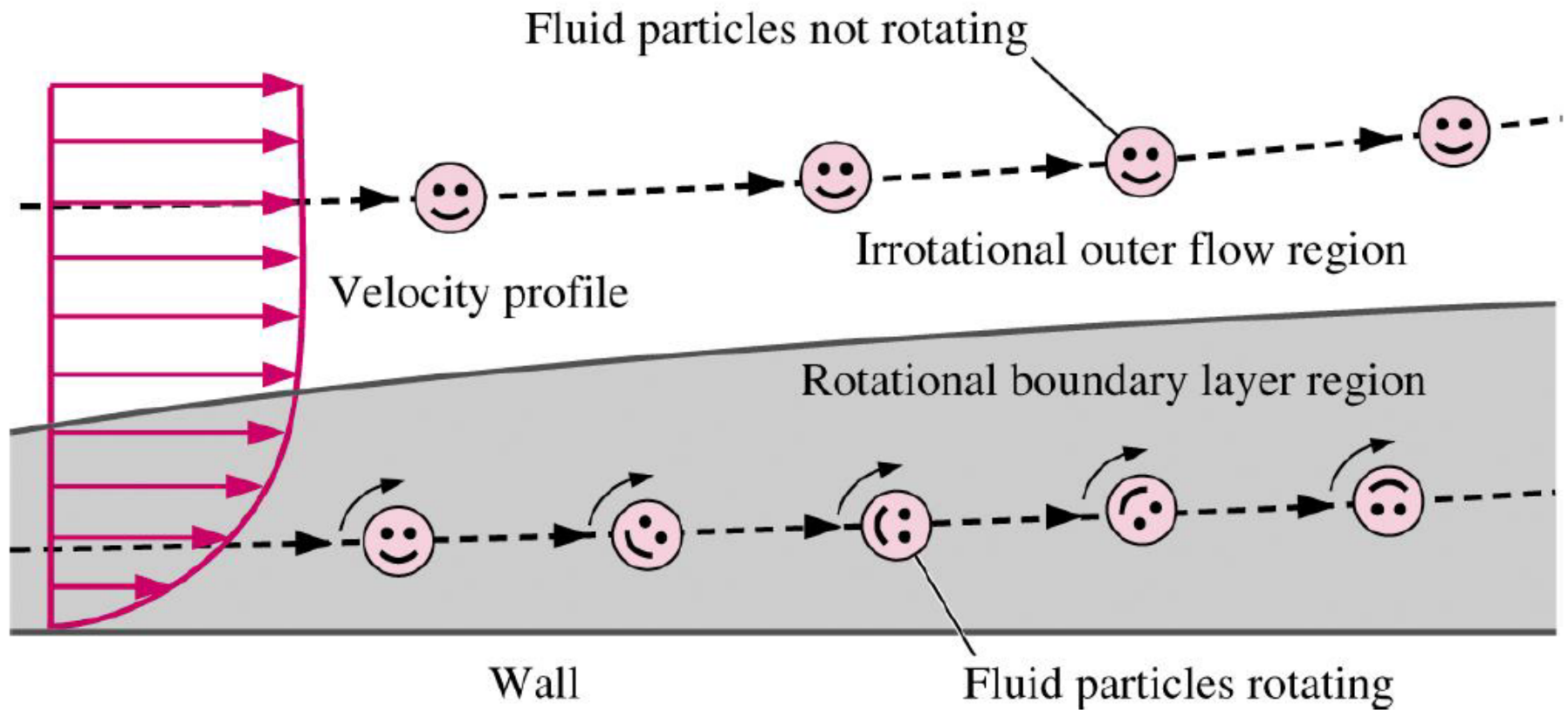

Circulation and vorticity

Stokes' theorem

$$\Gamma = \oint_C \mathbf{v} \cdot d\mathbf{l} = \int_A (\nabla \times \mathbf{v}) \cdot \mathbf{n} dA$$

i.e. if $\zeta = 0 \Rightarrow \Gamma = 0$

Flows for which $\zeta = 0$ are *irrotational*.

Stream tubes and vortex tubes

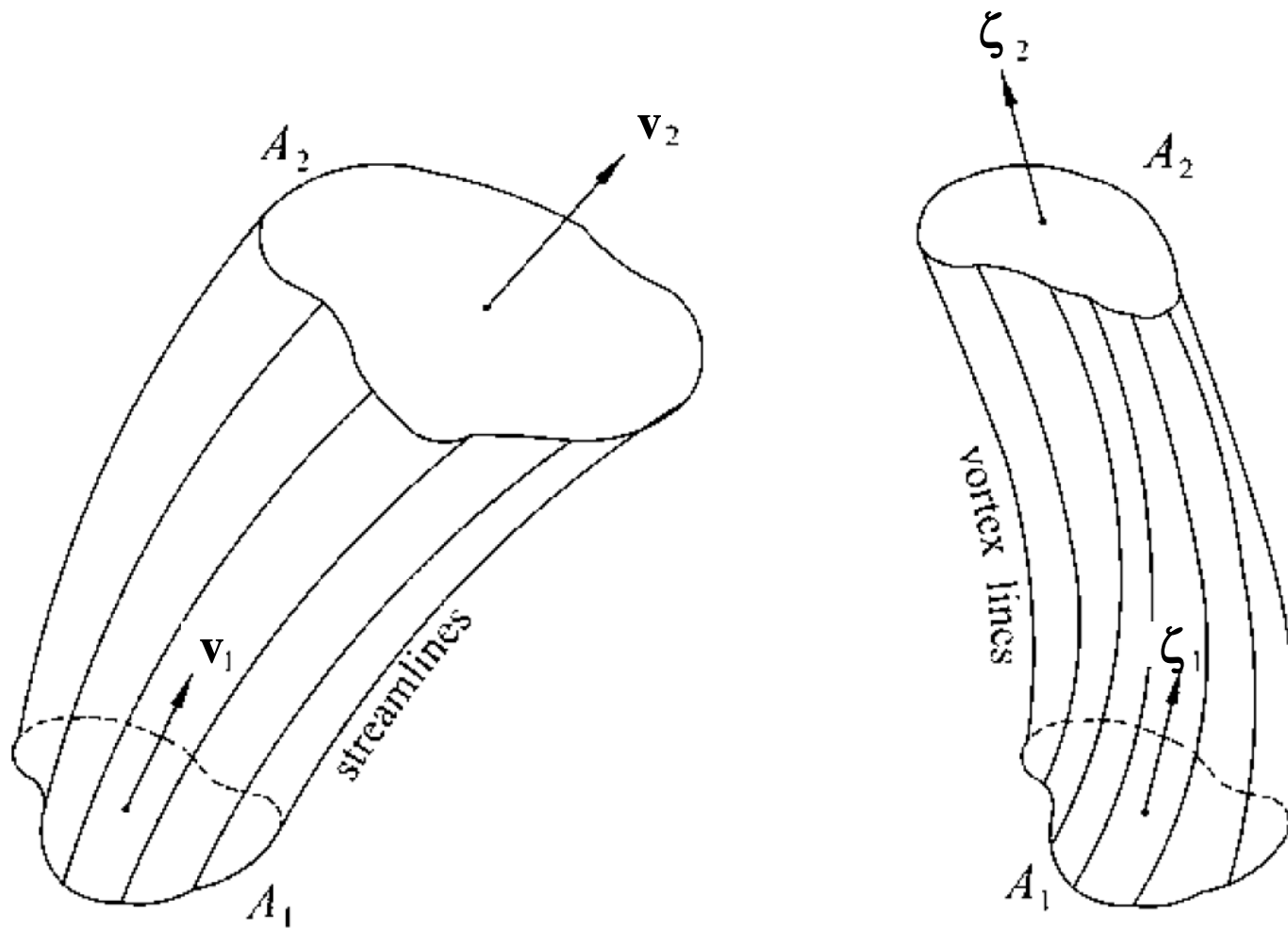

Stream filament and vortex filament

If $A_I \rightarrow 0$

we have, respectively, a *stream filament* and a *vortex filament*.

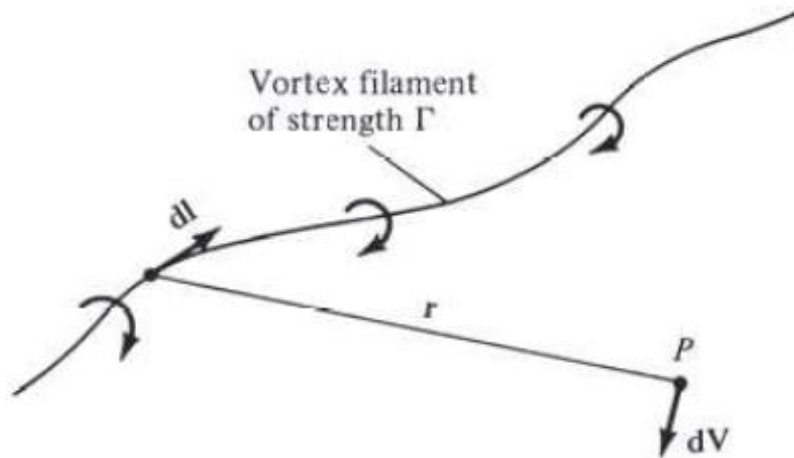

$$d\mathbf{V} = \frac{\Gamma}{4\pi} \frac{d\mathbf{l} \times \mathbf{r}}{|\mathbf{r}|^3}$$

Biot Savart law

Kinematics of vortex lines

Since the divergence of the curl of a vector is zero (by definition, show it!) it is:

$$\nabla \cdot \zeta = 0$$

This means that there are **no sources or sinks** of vorticity in the fluid \longrightarrow the vortex lines must either form closed loops or terminate on the boundaries (solid surface or free surface) of the fluid.

Correspondence velocity-vorticity

$$\boldsymbol{\zeta} \quad \longrightarrow \quad \nabla \cdot \boldsymbol{\zeta} = \mathbf{0} \quad \longrightarrow \quad \Gamma$$

$$\mathbf{v} \quad \longrightarrow \quad \nabla \cdot \mathbf{v} = \mathbf{0} \quad \longrightarrow \quad \dot{V}$$

Correspondence velocity-vorticity

Incompressible flow: $\nabla \cdot \mathbf{v} = 0$

Let's integrate over the total volume V of a stream tube (whose total outer surface is s):

$$\int_V \nabla \cdot \mathbf{v} \, dV = 0 \quad \xrightarrow{\text{Gauss theorem}} \quad \int_s \mathbf{v} \cdot \mathbf{n} \, ds = 0$$

$$\int_{A_1} \mathbf{v} \cdot \mathbf{n} \, ds + \int_{A_2} \mathbf{v} \cdot \mathbf{n} \, ds = 0 \quad \Longrightarrow \quad \boxed{\dot{V}_1 = \dot{V}_2}$$

Correspondence velocity-vorticity

Vorticity is divergence-free: $\nabla \cdot \boldsymbol{\zeta} = 0$

Let's integrate over the total volume V of a vortex tube (including the ends):

$$\int_V \nabla \cdot \boldsymbol{\zeta} \, dV = 0 \quad \xrightarrow{\text{Gauss theorem}} \quad \int_S \boldsymbol{\zeta} \cdot \mathbf{n} \, ds = 0$$

$$\int_{A_1} \boldsymbol{\zeta} \cdot \mathbf{n} \, ds + \int_{A_2} \boldsymbol{\zeta} \cdot \mathbf{n} \, ds = 0 \quad \Longrightarrow \quad \boxed{\Gamma_1 = \Gamma_2}$$

Helmholtz's theorems (1858)

The circulation Γ at each cross-section of a vortex tube (or filament) is the same; alternatively, the average vorticity increases as the cross-section of the vortex tube decreases: $\zeta_1 A_1 = \zeta_2 A_2$

Helmholtz's first theorem

the strength of a vortex filament is constant along its length, i.e. Γ is an invariant of the motion

Helmholtz's theorems (1858)

Helmholtz's second theorem

A vortex filament cannot end in a fluid; it must extend to the boundaries of the fluid or form a closed path



Helmholtz's theorems (1858)

Helmholtz's third theorem

In the absence of rotational external forces, a fluid that is initially irrotational remains irrotational, i.e. fluid parcels free of vorticity remain free of vorticity.

Kelvin's circulation theorem (1869)

In an ideal fluid which is either barotropic [$p = g(\rho)$] or at constant density, with conservative body forces, the circulation around a closed curve (which encloses the same fluid elements) moving with the fluid remains constant with time:

$$\frac{D\Gamma}{Dt} = 0$$

Kelvin's circulation theorem (1869)

$$\Gamma(t) = \oint_{C(t)} \mathbf{v} \cdot d\mathbf{l}$$

Euler equation, with conservative body force:

$$\frac{Dv_j}{Dt} = -\frac{1}{\rho} \frac{\partial p}{\partial x_j} + \frac{\partial G}{\partial x_j}$$

$$\frac{D\Gamma}{Dt} = \frac{D}{Dt} \oint_{C(t)} v_j dx_j = \oint_{C(t)} \left[\frac{Dv_j}{Dt} dx_j + v_j \frac{D(dx_j)}{Dt} \right]$$

Kelvin's circulation theorem (1869)

$$\frac{D(dx_j)}{Dt} = d\left(\frac{Dx_j}{Dt}\right) = d\left(\cancel{\frac{\partial x_j}{\partial t}} + v_k \frac{\partial x_j}{\partial x_k}\right) = dv_j$$

$$\begin{aligned} \Rightarrow \frac{D\Gamma}{Dt} &= \oint_{C(t)} \left[\frac{Dv_j}{Dt} dx_j + v_j dv_j \right] \\ &= \oint_{C(t)} \left(-\frac{1}{\rho} \frac{\partial p}{\partial x_j} dx_j + \frac{\partial G}{\partial x_j} dx_j + v_j dv_j \right) \\ &= \oint_{C(t)} \left[-\frac{dp}{\rho} + dG + \frac{1}{2} d(v_j v_j) \right] \end{aligned}$$

Kelvin's circulation theorem (1869)

$$(\partial p / \partial x_j) dx_j = dp$$

$$(\partial G / \partial x_j) dx_j = dG$$

total spatial variation
of p and G

Integrations are carried out on the closed contour $C(t)$ and, since the velocity and the body force are single-values, we are left with:

$$\frac{D\Gamma}{Dt} = - \oint_{C(t)} \frac{dp}{\rho}$$

Kelvin's circulation theorem (1869)

If the density is constant it is easy to see that the material derivative of Γ vanishes. If the field is barotropic, $p = g(\rho)$, then $dp = g'(\rho)d\rho$

$$\frac{D\Gamma}{Dt} = - \oint_{C(t)} \frac{g'(\rho)}{\rho} d\rho = \mathbf{0}$$

which can be stated as follows: *if we follow a given contour as it moves with the fluid, the total vorticity inside that contour does not change* (KCT).

Total vorticity could change because of (i) viscous effects, (ii) non-conservative body forces, or (iii) density variations not due to δp .

Consequences of KCT

$\frac{D\Gamma}{Dt} = 0$ implies that

any closed contour $C(t)$ in a fluid has a definite value of Γ which does not change as the contour moves and is deformed by the flow.

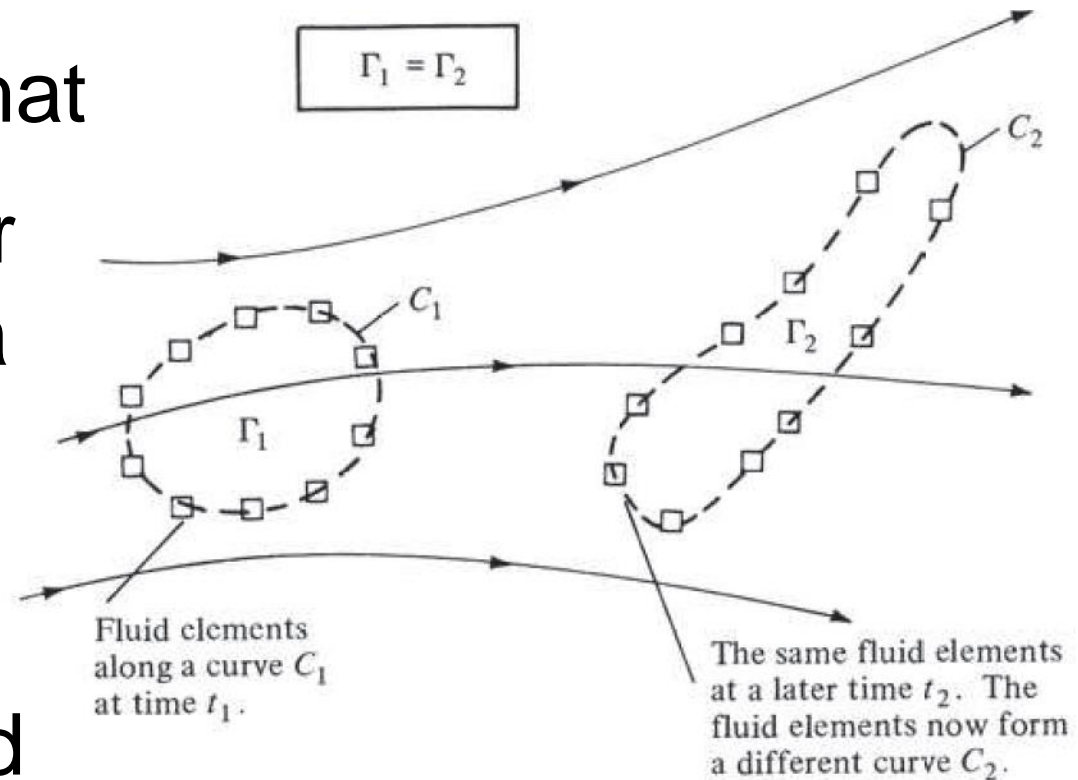

Consequences of KCT

$$\frac{D\Gamma}{Dt} = 0$$

implies that any closed contour $C(t)$ in a fluid has a definite value of Γ which does not change as the contour moves and is deformed by the flow.

If at a given time there is no body inside the contour, it will not enter the contour at later times. If there is a body initially ...

Consequences of KCT

$$\frac{D\Gamma}{Dt} = 0$$

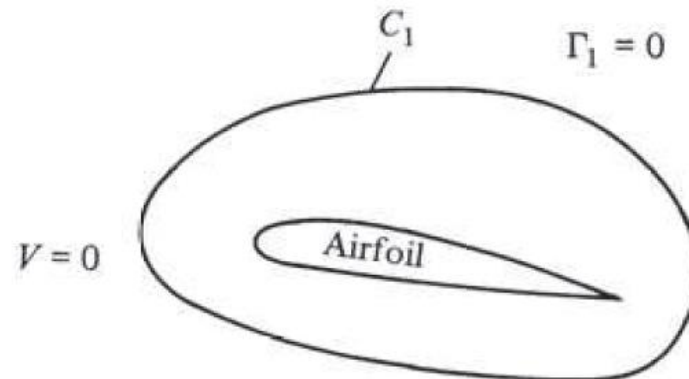

(a) Fluid at rest relative to the airfoil

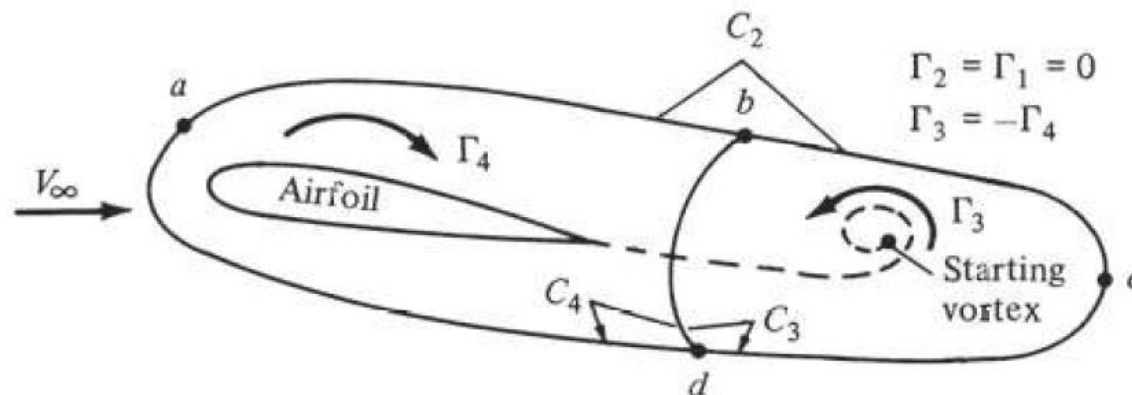

(b) Picture some moments after the start of the flow

Consequences of KCT

The ***starting vortex*** and the generation of lift

<https://youtu.be/bvV7-9wAXc0>

<https://youtu.be/VcggiVSf5F8>

The airfoil has circulation around it while immersed in an irrotational flow.

The vorticity equation

Navier-Stokes for a fluid of constant density and viscosity:

$$\frac{\partial \mathbf{v}}{\partial t} + (\mathbf{v} \cdot \nabla) \mathbf{v} = -\nabla \left(\frac{p}{\rho} \right) + \nu \nabla^2 \mathbf{v}$$

$$\frac{\partial \mathbf{v}}{\partial t} + \nabla \left(\frac{1}{2} \mathbf{v} \cdot \mathbf{v} \right) - \mathbf{v} \times (\nabla \times \mathbf{v}) = -\nabla \left(\frac{p}{\rho} \right) + \nu \nabla^2 \mathbf{v}$$

and taking the curl: $\frac{\partial \boldsymbol{\zeta}}{\partial t} - \nabla \times (\mathbf{v} \times \boldsymbol{\zeta}) = \nu \nabla^2 \boldsymbol{\zeta}$

(curl grad = 0!)

The vorticity equation

Vector identity:

$$\nabla \times (\mathbf{v} \times \boldsymbol{\zeta}) = \mathbf{v}(\nabla \cdot \boldsymbol{\zeta}) - \boldsymbol{\zeta}(\nabla \cdot \mathbf{v}) - (\mathbf{v} \cdot \nabla)\boldsymbol{\zeta} + (\boldsymbol{\zeta} \cdot \nabla)\mathbf{v}$$

$$\underbrace{\frac{\partial \boldsymbol{\zeta}}{\partial t} + (\mathbf{v} \cdot \nabla)\boldsymbol{\zeta}}_{\text{convection of vorticity from the flow}} = \underbrace{(\boldsymbol{\zeta} \cdot \nabla)\mathbf{v}}_{\text{vorticity stretching/tilting}} + \underbrace{\nu \nabla^2 \boldsymbol{\zeta}}_{\text{viscous diffusion}}$$

The vorticity equation

2D flows: the vorticity is orthogonal to the plane where the velocity is defined, hence

$$\boldsymbol{\zeta} \cdot \nabla \mathbf{v} = 0$$

The vorticity equation (both 2D and 3D flows) does not have the pressure in it. Pressure can be found *a posteriori* from:

$$\nabla^2 \left(\frac{p}{\rho} \right) = \boldsymbol{\zeta} \cdot \boldsymbol{\zeta} + \mathbf{v} \cdot (\nabla^2 \mathbf{v}) - \frac{1}{2} \nabla^2 (\mathbf{v} \cdot \mathbf{v})$$

The vorticity equation

In **3D flows** the rotation and damping/
amplification term $\zeta \cdot \nabla \mathbf{v}$ is crucial.

It is known that $\nabla \mathbf{v} = \mathbf{E} + \mathbf{\Omega}$

symmetric strain
rate tensor

skew-symmetric
rotation rate tensor

with $\nabla \mathbf{v}$ thus related to deformation
and rotation rates in the fluid.

The vorticity equation

$$\zeta \cdot \nabla \mathbf{v} = \zeta \cdot \mathbf{E} + \zeta \cdot \boldsymbol{\Omega}$$

show this!

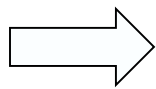

$$\frac{\partial \zeta}{\partial t} + (\mathbf{v} \cdot \nabla) \zeta = \underbrace{\zeta \cdot \mathbf{E}} + \nu \nabla^2 \zeta$$

damping/amplification of vorticity of vorticity, plus tilting of the axis of the vortex tube because of the action of strain rate

The vorticity equation

$$\frac{\partial \zeta}{\partial t} + (\mathbf{v} \cdot \nabla) \zeta = \underbrace{\zeta \cdot \mathbf{E}} + \nu \nabla^2 \zeta$$

this term is a source/sink of vorticity
(absent in 2D)

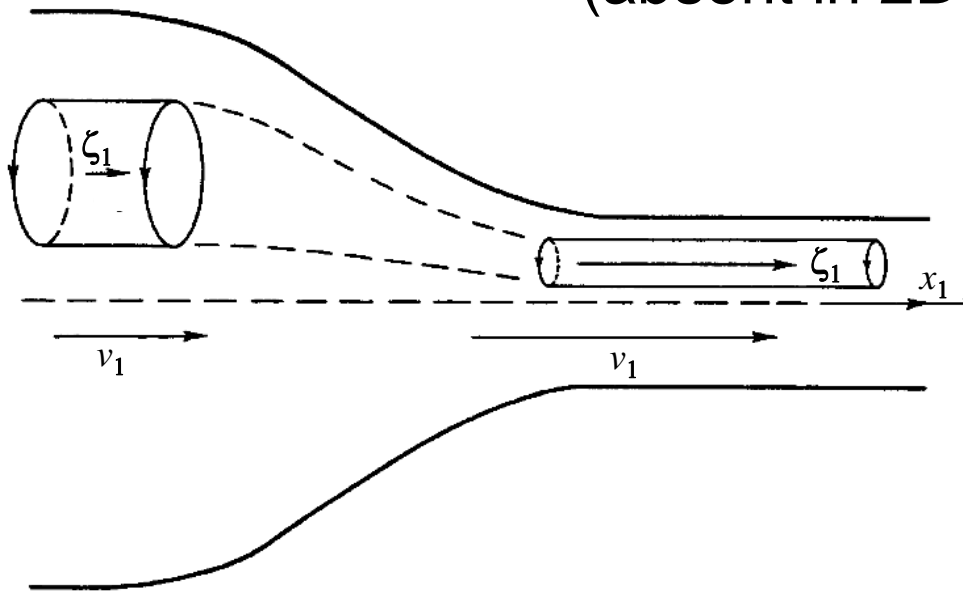

$$\varepsilon_{11} = \frac{\partial v_1}{\partial x_1} > 0$$

↓

ζ_1

The vorticity equation

By Kelvin's theorem (*inviscid and barotropic fluid, conservative body forces*), the circulation on a material line around any section of the vortex tube is conserved. Thus the reduction in section of the tube brings with it an increase in vorticity. As the vortex tube is stretched (deformation work made by \mathbf{E}) we

have an increase of the average vorticity.

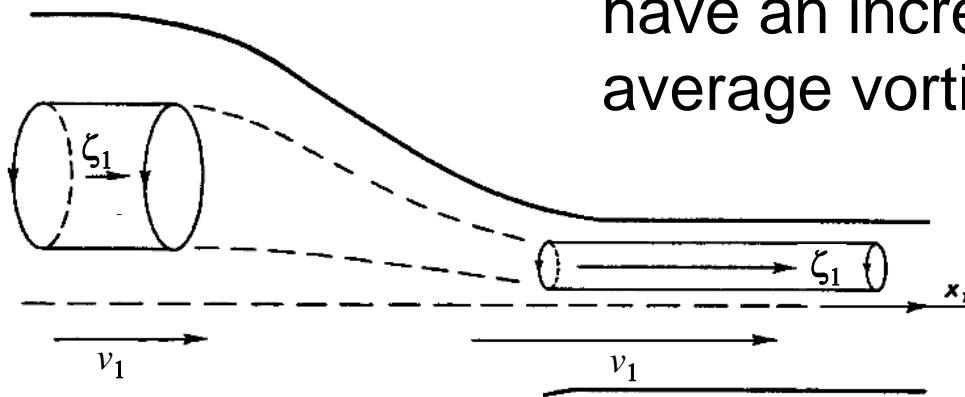

Other interpretation: *conservation of angular momentum.*

Stretching of material surface \implies section $\downarrow \implies$ moment of inertia $\downarrow \implies$ angular velocity \uparrow

Exercise

Competition between linear strain of a viscous axisymmetric vortex and viscous diffusion

Let us consider a system of cylindrical coordinates (r, θ, z) and an axisymmetric ($\partial/\partial\theta = 0$) vortex tube aligned with z . The tube has a single component of vorticity (along z), which is $\omega = \omega(r, t)$, t being the independent time variable. The velocity field is a linear strain field, with the z component given by $v_z = \alpha z$, α a positive constant.

1. Starting from the vorticity equation, and focusing on the source/sink terms of vorticity, find the conditions under which the vorticity remains aligned with z , i.e. the source terms of the components of the vorticity equation along r and θ vanish. For these conditions find the radial and azimuthal components of the velocity, v_r and v_θ .
2. The vorticity equation becomes a scalar equation for $\zeta_z = \omega$, and it can be easily integrated in the steady case. Show that

$$\omega = \omega_1 \exp(-\alpha r^2/4\nu).$$

3. Using Kelvin's circulation theorem show that $\omega_1 \approx \omega_0 \frac{\alpha r_0^2}{4\nu}$, where r_0 is the radius of the initial vorticity distribution and ω_0 the initial amplitude. This means that ω_1 (maximum value of vorticity at $r = 0$) increases with stretching (i.e. with α) and decreases with viscosity ν . The amplification of ω is accompanied (and limited) by viscous diffusion, i.e. the vortex widens radially.

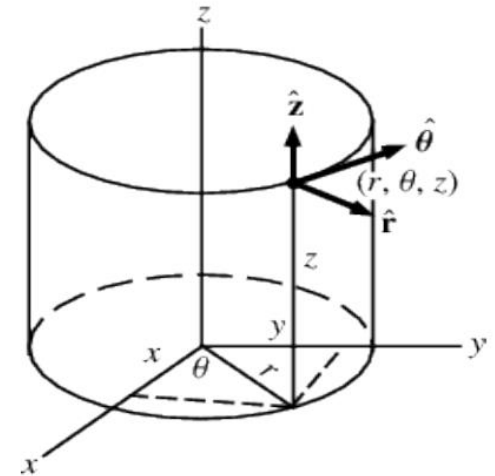

Exercise

Competition between linear strain of a viscous axisymmetric vortex and viscous diffusion

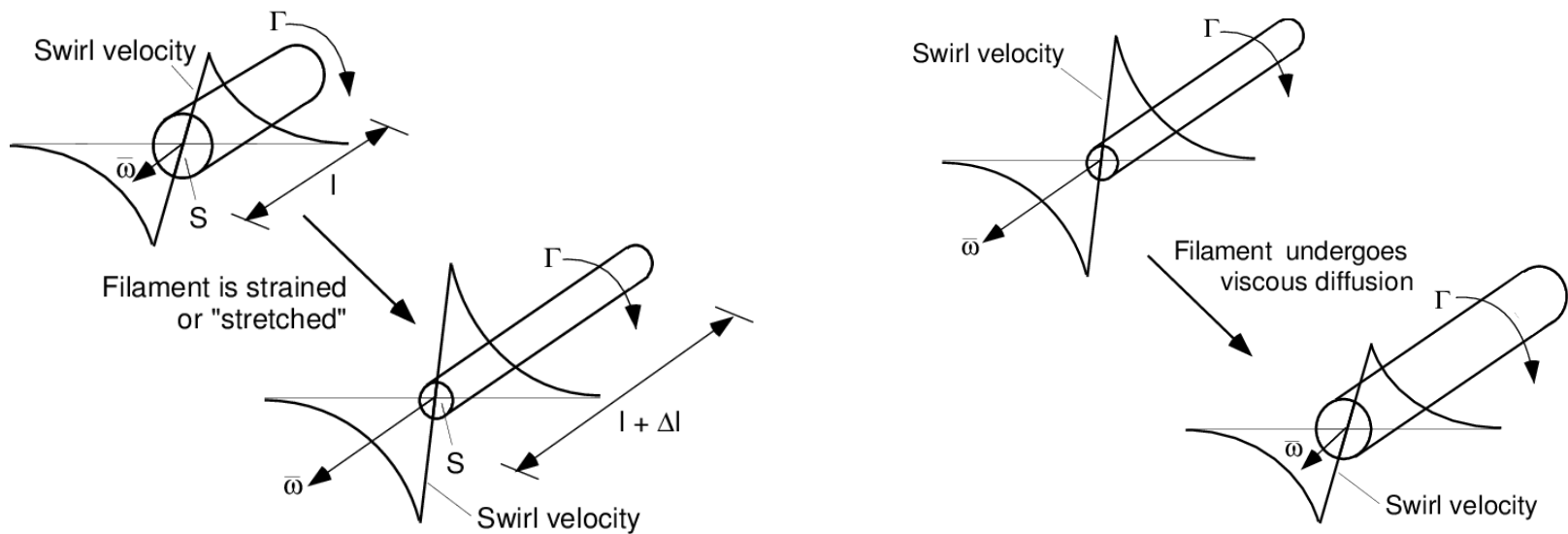

Exercise

Competition between linear strain of a viscous axisymmetric vortex and viscous diffusion

$$v_r = -\frac{\alpha r}{2}, \quad v_\theta = \frac{1}{r} \int_0^r \rho \omega(\rho, t) d\rho = \dots \approx \frac{\omega_0 r^2}{2r} \left[1 - e^{-\frac{\alpha r^2}{4\nu}} \right]$$

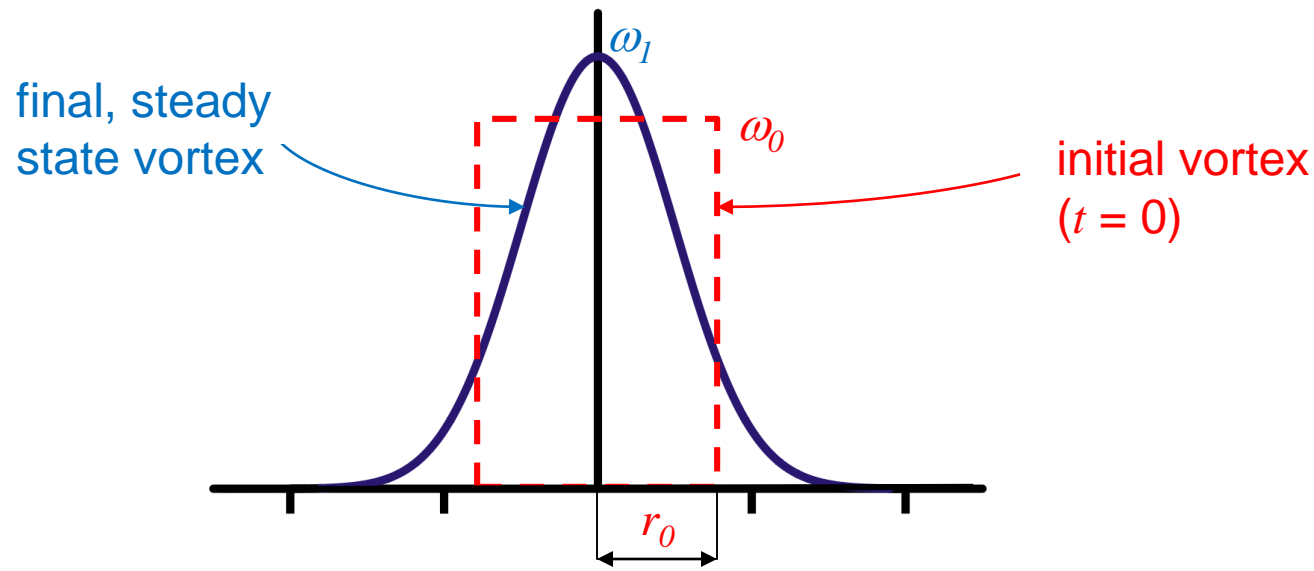

3D vorticity equation, cylindrical coordinates

$$\frac{\partial \zeta}{\partial t} + (\mathbf{v} \cdot \nabla) \zeta = \underbrace{(\zeta \cdot \nabla) \mathbf{v}}_{\text{source/sink}} + \nu \nabla^2 \zeta \quad \left\{ \begin{array}{l} \zeta = (\zeta_r, \zeta_\theta, \zeta_z) \\ \mathbf{v} = (v_r, v_\theta, v_z) \end{array} \right.$$

In cylindrical coordinates (r, θ, z) the source/sink term reads

$$\mathbf{e}_r \left(\zeta \cdot \nabla v_r - \frac{\zeta_\theta v_\theta}{r} \right) + \mathbf{e}_\theta \left(\zeta \cdot \nabla v_\theta + \frac{\zeta_\theta v_r}{r} \right) + \mathbf{e}_z (\zeta \cdot \nabla v_z)$$

and the vorticity is

$$\zeta = \mathbf{e}_r \left(\frac{1}{r} \frac{\partial v_z}{\partial \theta} - \frac{\partial v_\theta}{\partial z} \right) + \mathbf{e}_\theta \left(\frac{\partial v_r}{\partial z} - \frac{\partial v_z}{\partial r} \right) + \mathbf{e}_z \left(\frac{1}{r} \frac{\partial (r v_\theta)}{\partial r} - \frac{1}{r} \frac{\partial v_r}{\partial \theta} \right)$$

Appendix A: vector identities

In the following formulas, ϕ is any scalar and \mathbf{a} , \mathbf{b} , and \mathbf{c} are any vectors.

$$\nabla \times \nabla \phi = \mathbf{0}$$

$$\nabla \cdot (\phi \mathbf{a}) = \phi \nabla \cdot \mathbf{a} + \mathbf{a} \cdot \nabla \phi$$

$$\nabla \times (\phi \mathbf{a}) = \nabla \phi \times \mathbf{a} + \phi (\nabla \times \mathbf{a})$$

$$\nabla \cdot (\nabla \times \mathbf{a}) = 0$$

$$(\mathbf{a} \cdot \nabla) \mathbf{a} = \frac{1}{2} \nabla (\mathbf{a} \cdot \mathbf{a}) - \mathbf{a} \times (\nabla \times \mathbf{a})$$

$$\nabla \times (\nabla \times \mathbf{a}) = \nabla (\nabla \cdot \mathbf{a}) - \nabla^2 \mathbf{a}$$

$$\nabla \times (\mathbf{a} \times \mathbf{b}) = \mathbf{a} (\nabla \cdot \mathbf{b}) - \mathbf{b} (\nabla \cdot \mathbf{a}) - (\mathbf{a} \cdot \nabla) \mathbf{b} + (\mathbf{b} \cdot \nabla) \mathbf{a}$$

$$\nabla \cdot (\mathbf{a} \times \mathbf{b}) = \mathbf{b} \cdot (\nabla \times \mathbf{a}) - \mathbf{a} \cdot (\nabla \times \mathbf{b})$$

Appendix B: integral theorems

In the following two theorems, which relate surface integrals to volume integrals, V is any volume and S is the surface that encloses V , the unit normal on S being denoted by \mathbf{n} . ϕ is any scalar and \mathbf{a} is any vector.

Gauss' theorem: (also known as the divergence theorem):

$$\int_S \mathbf{a} \cdot \mathbf{n} dS = \int_V \nabla \cdot \mathbf{a} dV$$

Green's theorem:

$$\int_S \phi \frac{\partial \phi}{\partial n} dS = \int_V [\nabla \phi \cdot \nabla \phi + \phi \nabla^2 \phi] dV$$

Stokes' theorem:

$$\oint \mathbf{a} \cdot d\mathbf{l} = \int_A (\nabla \times \mathbf{a}) \cdot \mathbf{n} dA$$

This theorem relates a line integral to an equivalent surface integral. The surface A is arbitrary, but it must terminate on the line l .