



*CFD++ APPLICATION ON
WIND TUNNEL
DATA ANALYSIS*

Introduction

Piaggio Aero Industries is actually studying a new mid size jet for civilian use.

Many people and many disciplines are implicated but up to now aerodynamics is still holding a key role.

CFD and WT tests are usually combined and compared to validate each other and to understand local and global behaviour of the proposed shape for the aircraft .

In this scenario CFD ++ has an important place



First of all ...

It's necessary to clarify the purpose of the following presentation.

We illustrate here how we used CFD++ to analyze the wind tunnel data focusing in understanding what happens during the test and what can affect the acquisition precluding a direct comparison with numerical prediction.

We recognized only qualitatively two main phenomena characterizing the way we used to perform wind tunnel tests and that we recommend to take in account during other similar WT test.

Items

Using a scientific approach

- » WIND TUNNEL TEST DESCRIPTION
- » NUMERICAL – EXPERIMENTAL DATA COMPARISON
- » EXPERIMENTAL – EXPERIMENTAL DATA COMPARISON
- » NEXT STEPS and CONCLUSIONS

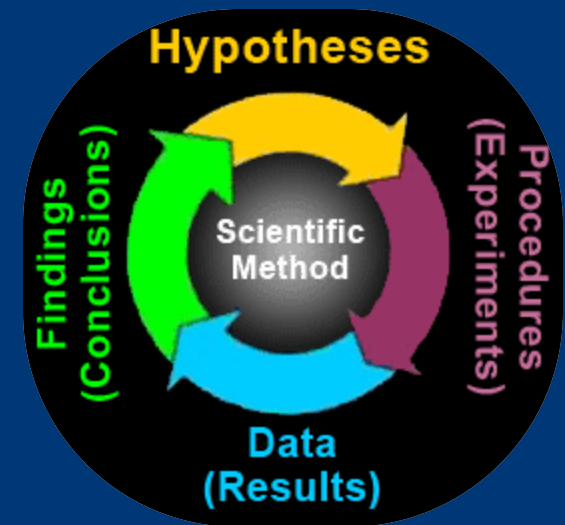

WIND TUNNEL TEST DESCRIPTION

✓ MODEL:

- STEEL MANUFACTURED MODEL OF A MEDIUM SIZE TRANSONIC BUSINESS JET
- SCALE 1:16.2

✓ FACILITIES:

- TRANSONIC PRESSURIZED WIND TUNNEL S2 O.N.E.R.A.
- INSTRUMENTATIONS:
 - ✓ 6 AXIS STRAIN GAUGED BALANCE
 - ✓ PSP (Pressure Sensitive Paint)

WIND TUNNEL TEST DESCRIPTION

✓ TESTS

- TESTING CONDITION

- ✓ $M = 0.8$
- ✓ $Re/m = 25.5 \cdot 10^6$
- ✓ $T = 300^\circ \text{ K}$

✓ TWO KIND OF TESTS

- a. FORCES AND MOMENT DATA ACQUISITION TESTING THE MODEL WITH NOT PAINTED SURFACES
- b. PRESSURE VISUALIZATION AND SIMULTANEOUS FORCES AND MOMENT DATA ACQUISITION TESTING A PSP PAINTED MODEL

NUMERICAL – EXPERIMENTAL
DATA COMPARISON
ON
CLEAN MODEL

NUMERICAL – EXPERIMENTAL DATA COMPARISON (1)

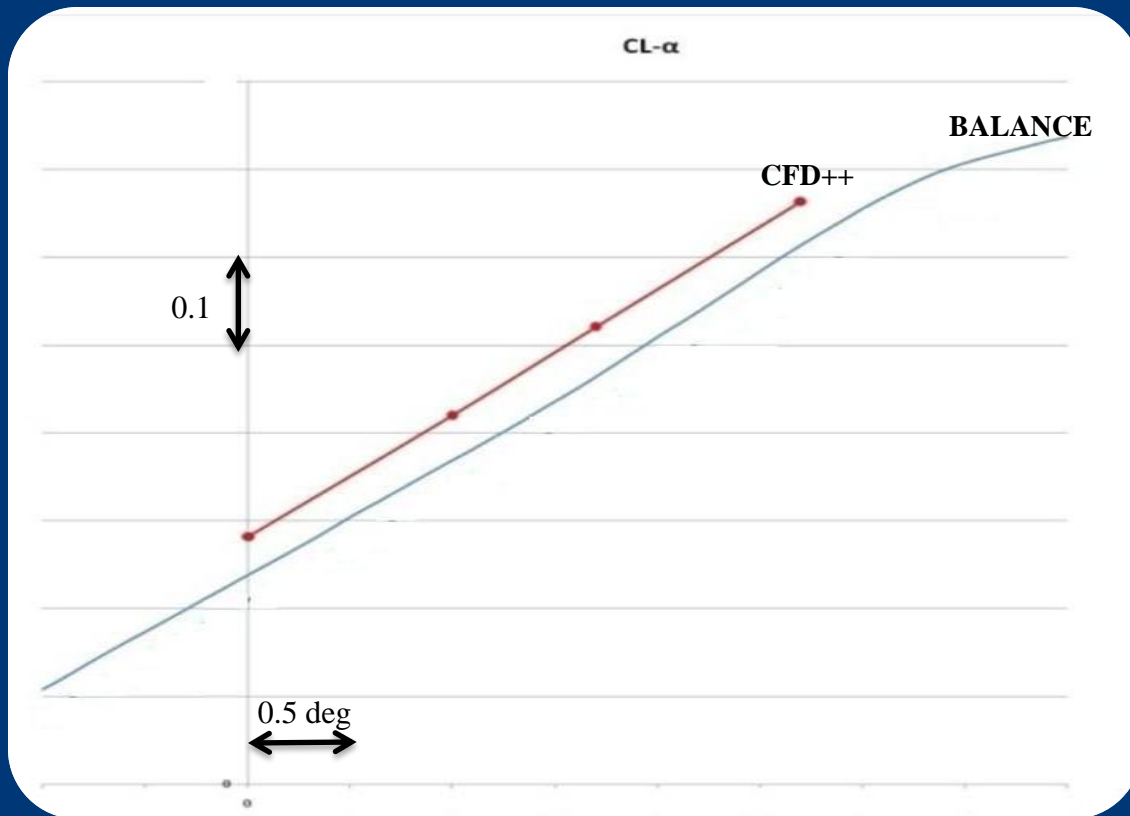

High differences between numerical and experimental data acquired on model with not painted surfaces

NUMERICAL – EXPERIMENTAL DATA COMPARISON (2)

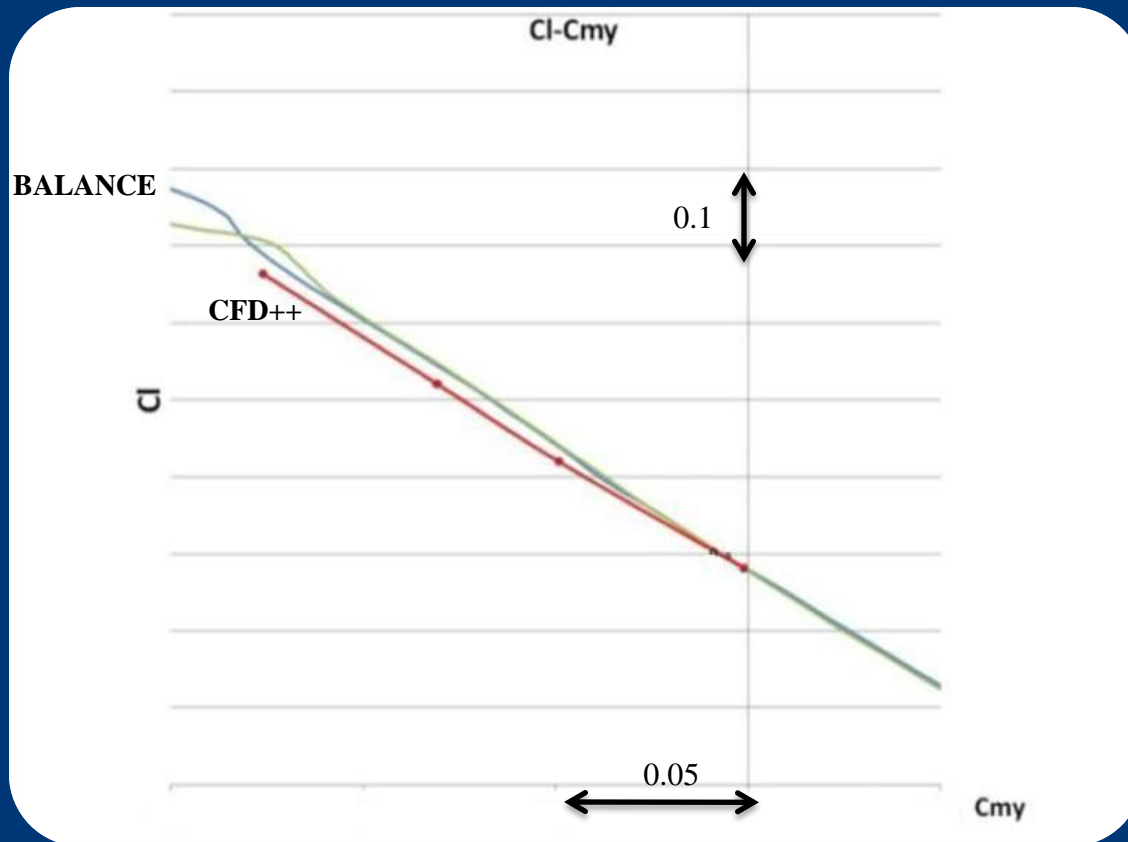

Lower numerical values for the lift coefficient are confirmed by this graph

NUMERICAL – EXPERIMENTAL DATA COMPARISON (3)

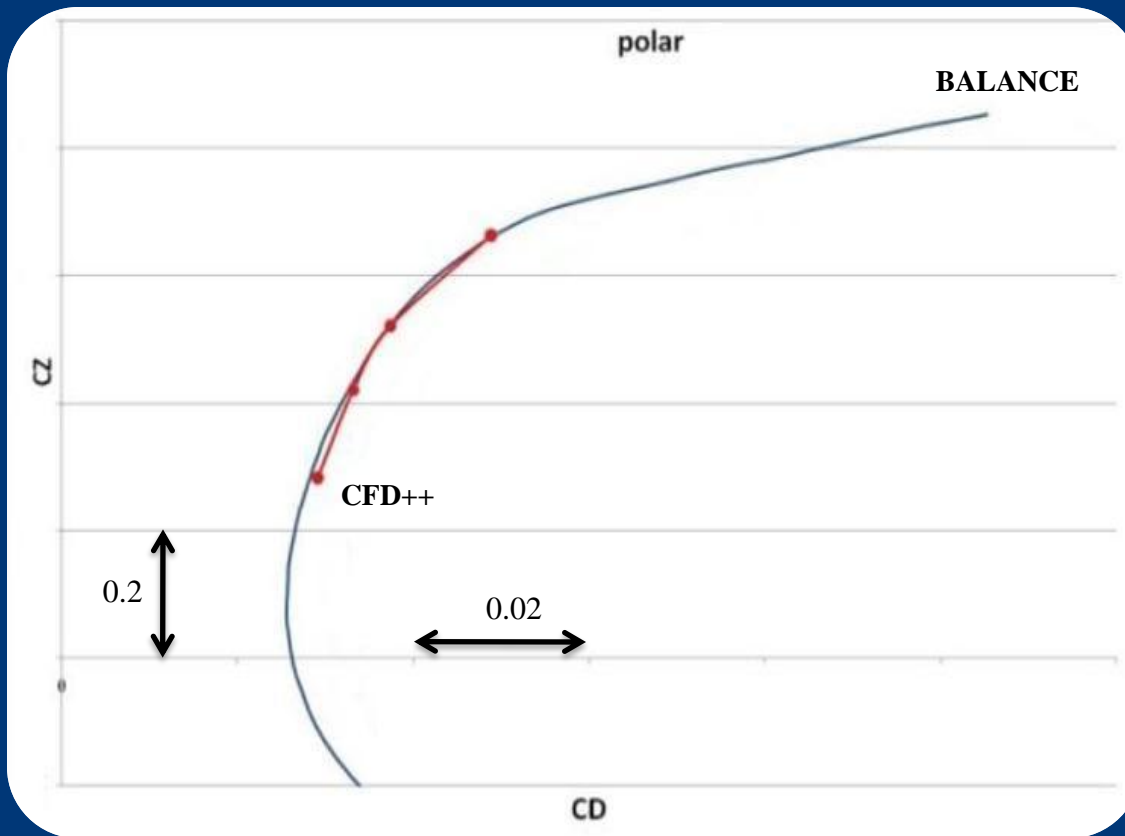

Interesting agreement
in data comparison
between CFD and
clean model WT test
can be observed in the
polar diagram

INVESTIGATION ON DIFFERENCES

Numerical and experimental integral values

- Observations on clean surfaces model experimental data and CFD++ predictions
 - Great differences on $CL - \alpha$ diagram
 - No differences on $CL - CD$ polar
 - Something happens respecting the $CL - CD$ relationship

- Hypothesis
 - Elastic twist deformation of the model emphasized by the sweep angle
→ static aeroelastic phenomena

STATIC AEROELASTIC PHENOMENA

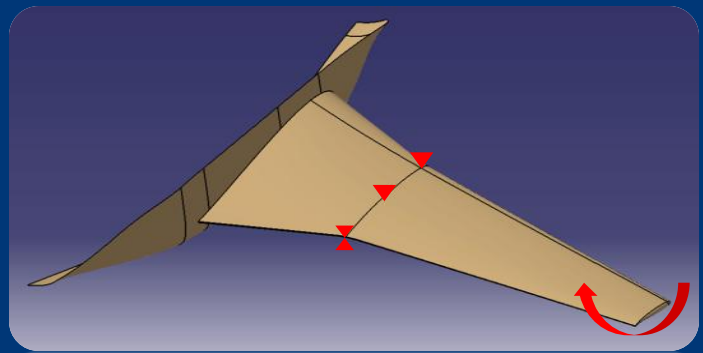

To verify our hypothesis we tried to apply a linear twist deformation starting from kink section up to the tip section considering bending deformation as a second order effect on aerodynamics

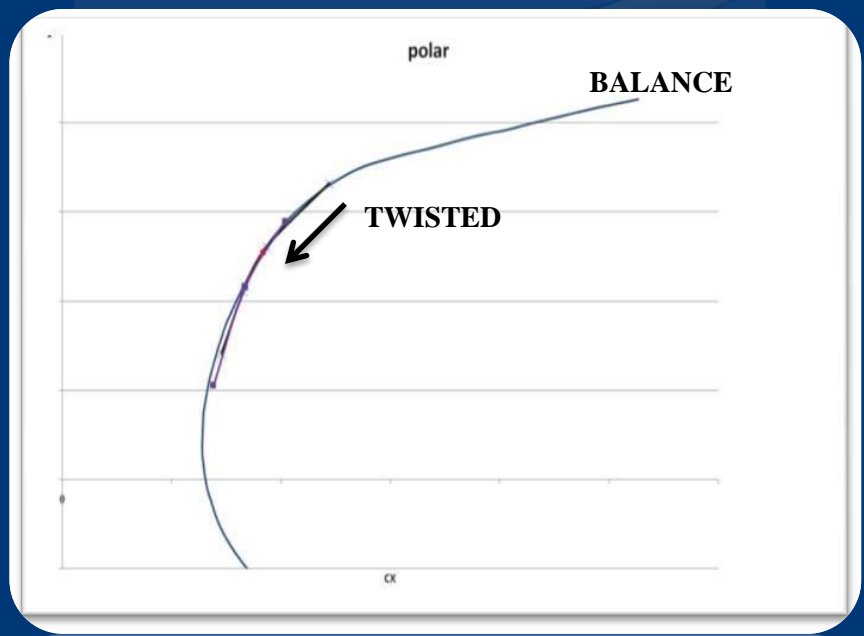

We obtained only a movement along the polar graph and...

STATIC AEROELASTIC PHENOMENA

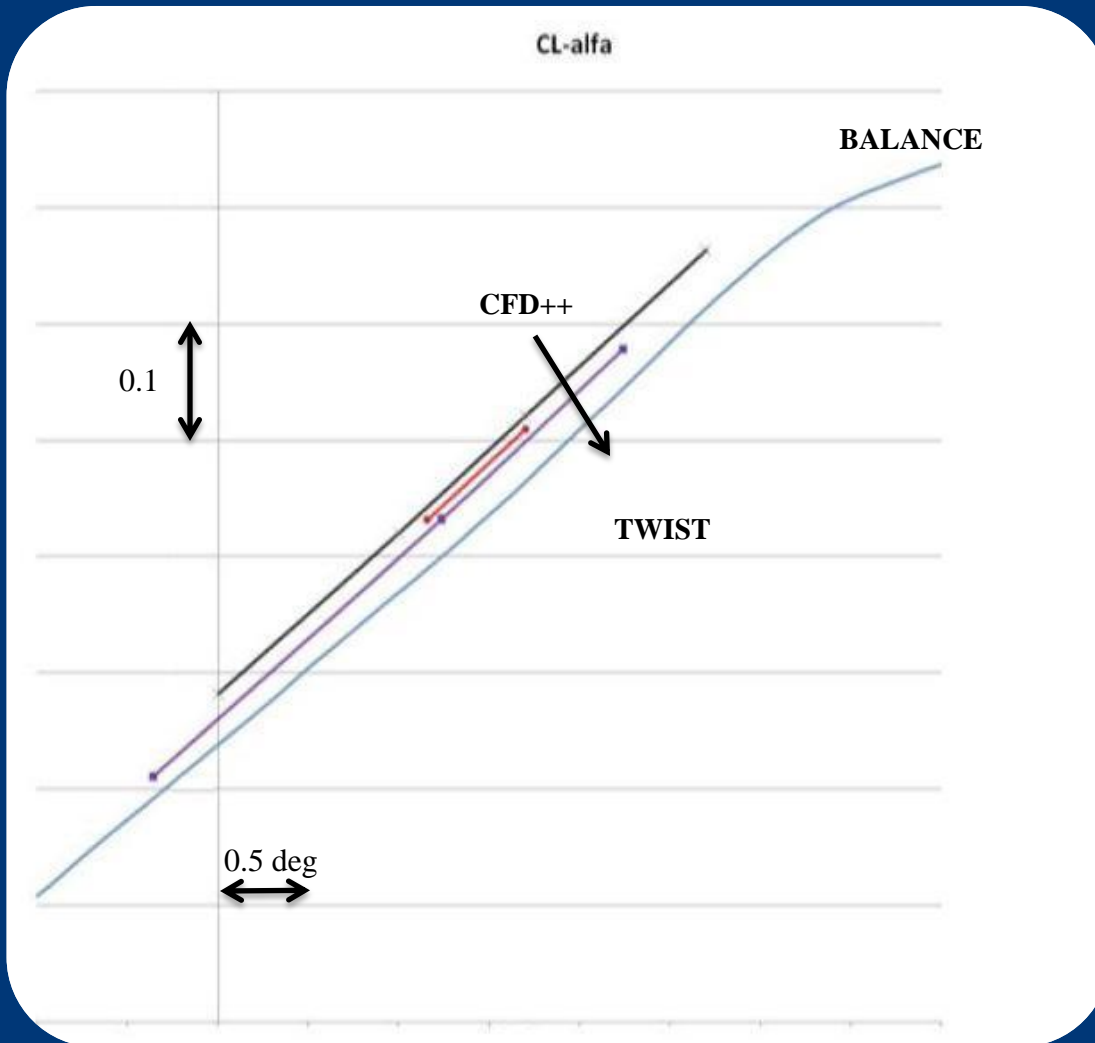

... a translation of the numerical CL – alpha curve toward the experimental one

STATIC AEROELASTIC PHENOMENA

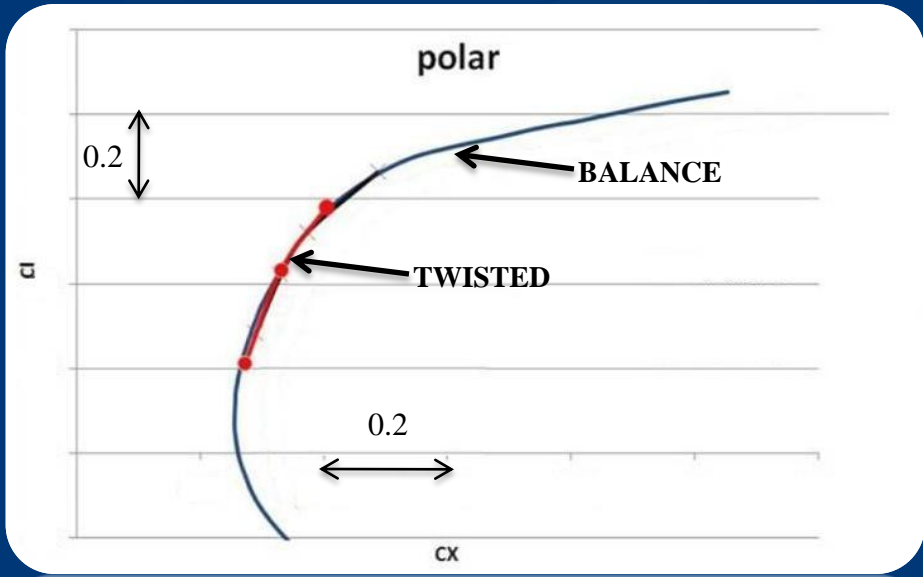
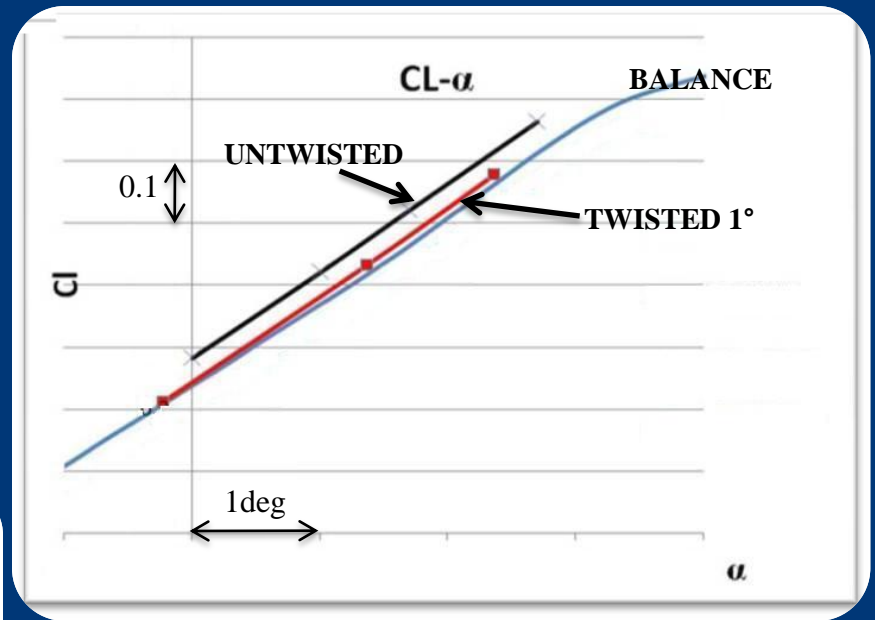
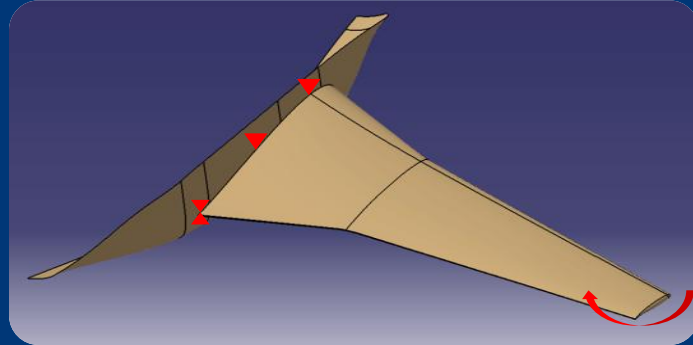

A better trend is observed twisting linearly the wing from the root up to the tip section.

STATIC AEROELASTIC PHENOMENA

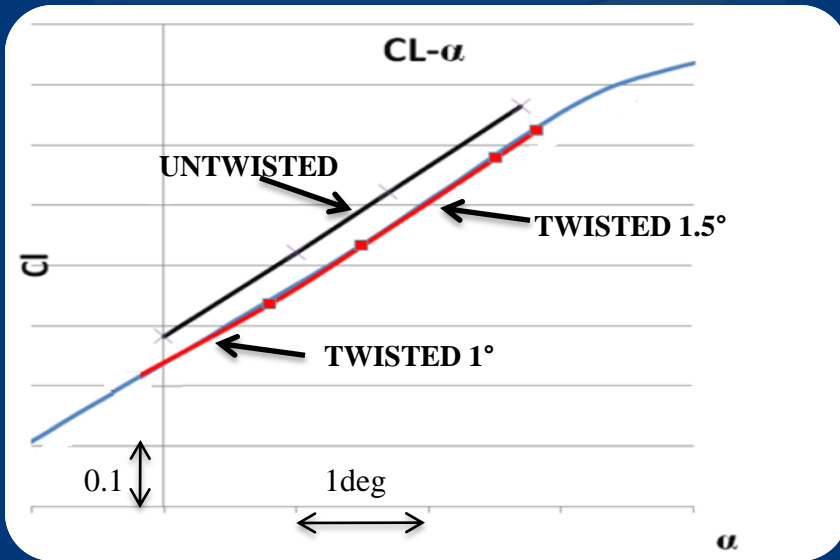
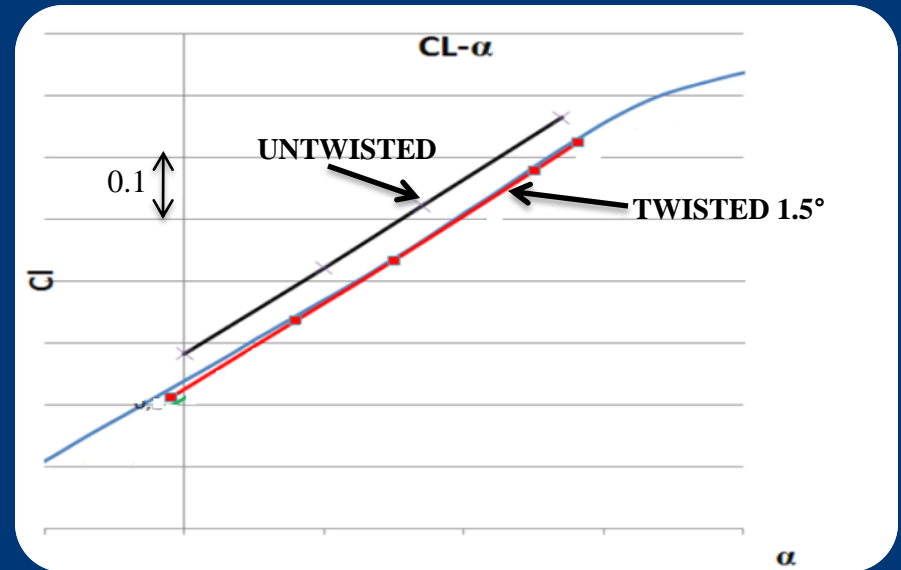
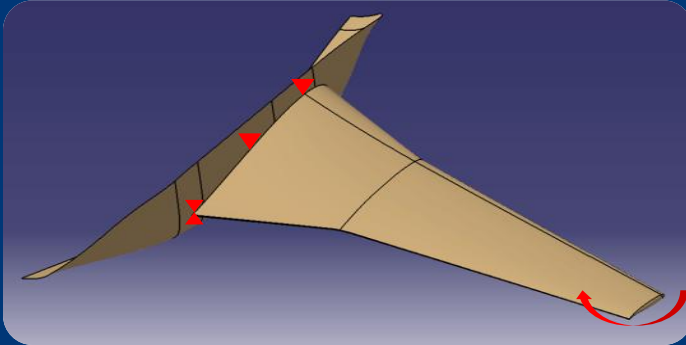

Combining a 1° twist at the tip section for lower angle of attack and 1.5° for the higher one we match the experimental data all over the test range

***EXPERIMENTAL – EXPERIMENTAL
DATA COMPARISON
BETWEEN
CLEAN AND PAINTED MODEL***

EXPERIMENTAL-EXPERIMENTAL DATA COMPARISON (1)

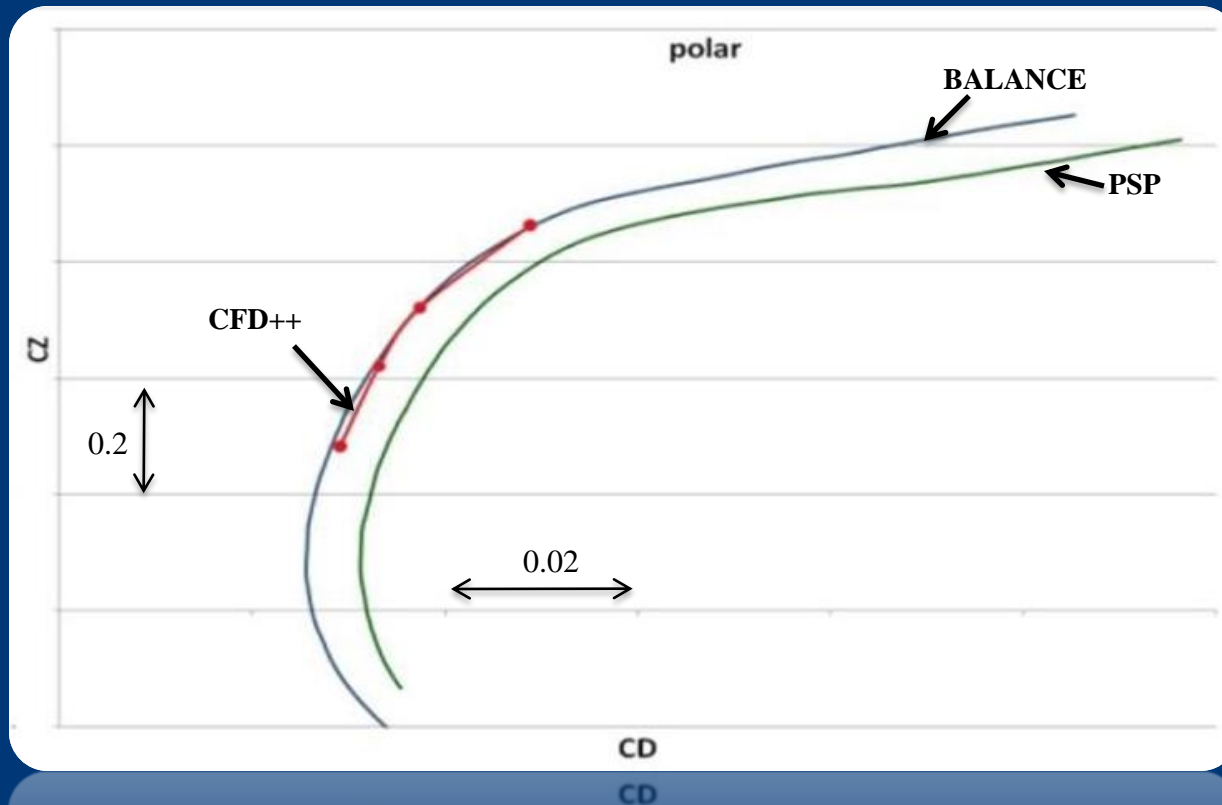

Surprising high differences between clean surfaces and PSP painted surfaces experimental integral values

EXPERIMENTAL – EXPERIMENTAL DATA COMPARISON (2)

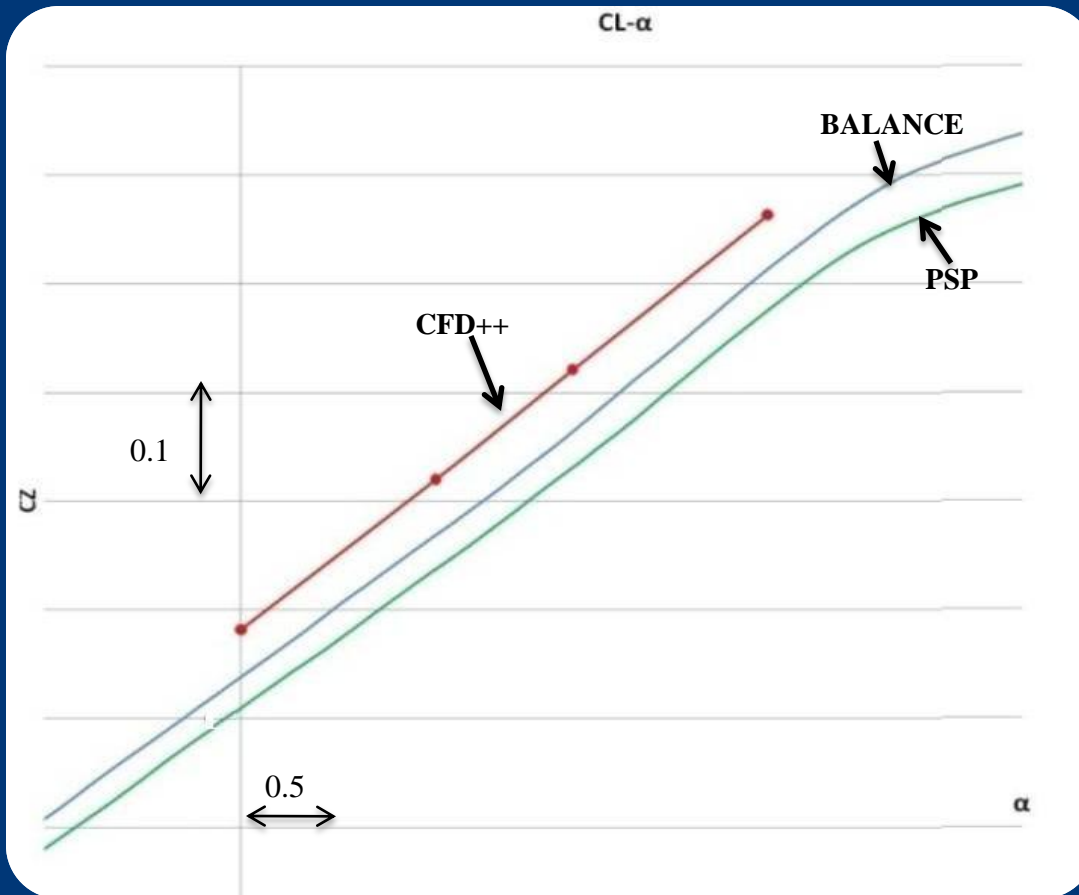

Not negligible differences between experimental integral values referred to clean surfaces and to PSP painted surfaces test conditions

INVESTIGATION ON DIFFERENCES

Experimental forces readed on balance

- Observations on tests performed with clean and painted model
 - Great difference on CL – α diagram
 - Great differences on CL – CD polar
 - Adding PSP increases CD and reduces CL

- Hypothesis
 - Airfoil thickness increases or surface roughness grows

TUNING CFD++

Roughness

Working on the undeformed wing we tuned the CFD++ code to reproduce the effect of PSP on the polar diagram

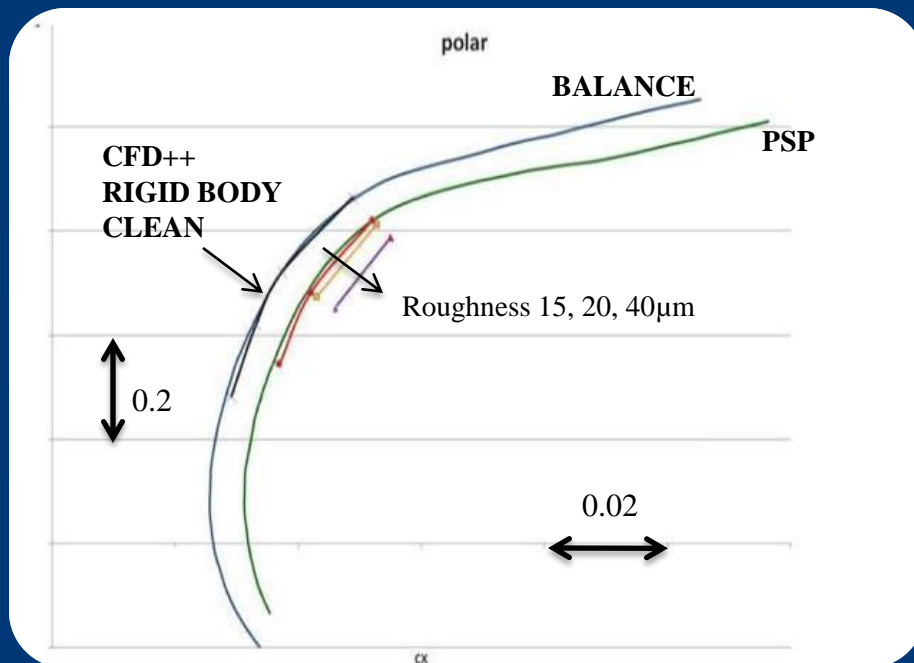

Simply adding roughness and using $15\mu\text{m}$ as a mean values the CFD++ integral results predict more exactly the experimental data for PSP painted model

TUNING CFD++

Roughness

...but a not negligible difference remains comparing numerical and experimental data on CL- α curves

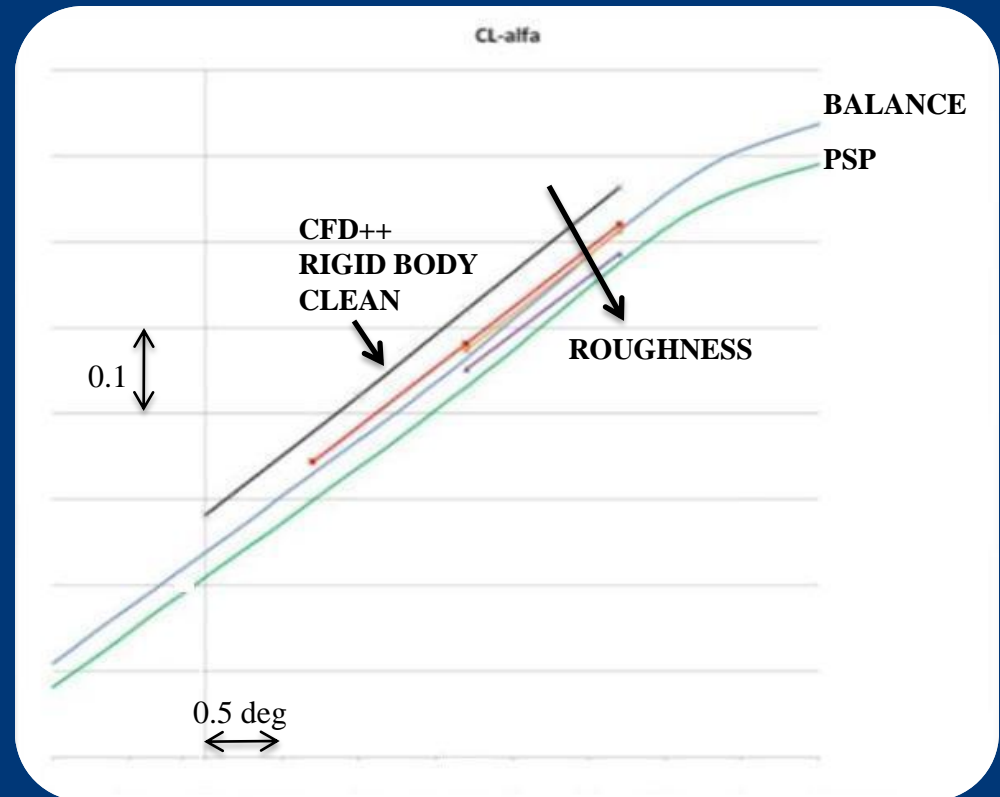

TUNING CFD++

Roughness

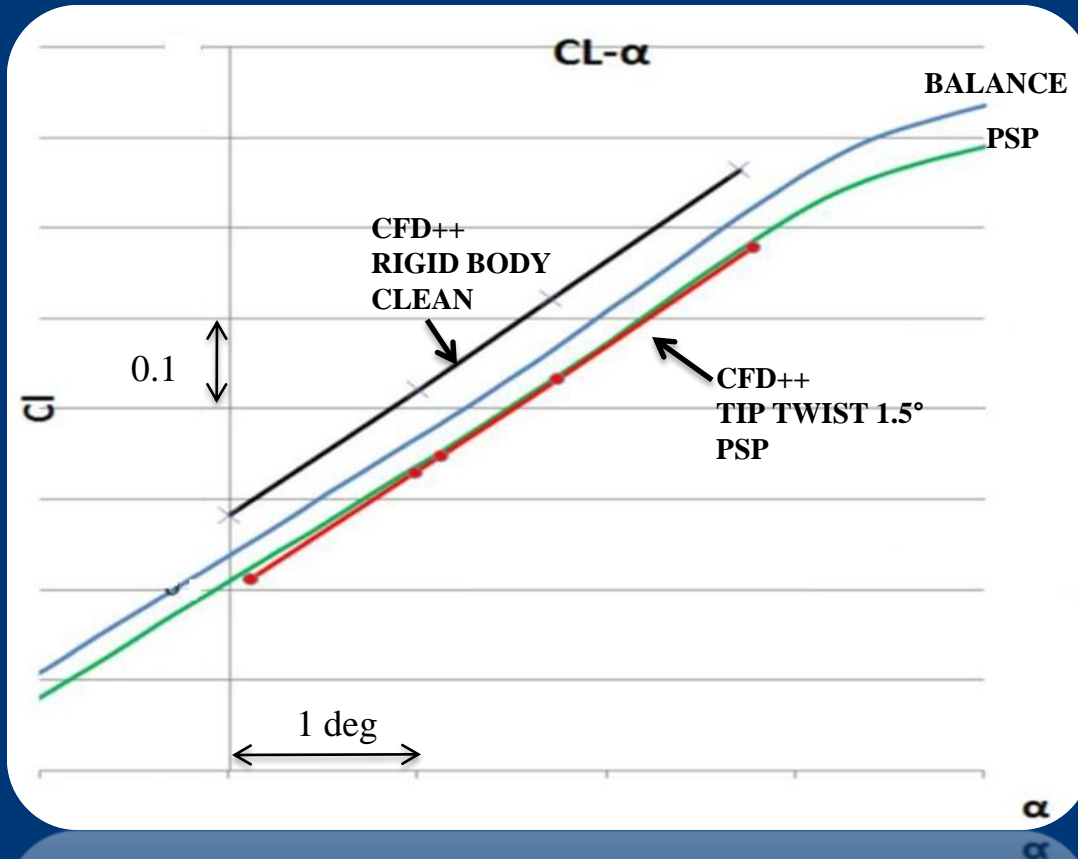

We have still to take in account the elastic deformation of the model. In fact, combining $13\mu\text{m}$ as a mean values roughness and the 1.5° twist at tip section, CFD++ produces a very good integral values prediction also in the C_L - α diagram

CONCLUSIONS

Pressure distribution

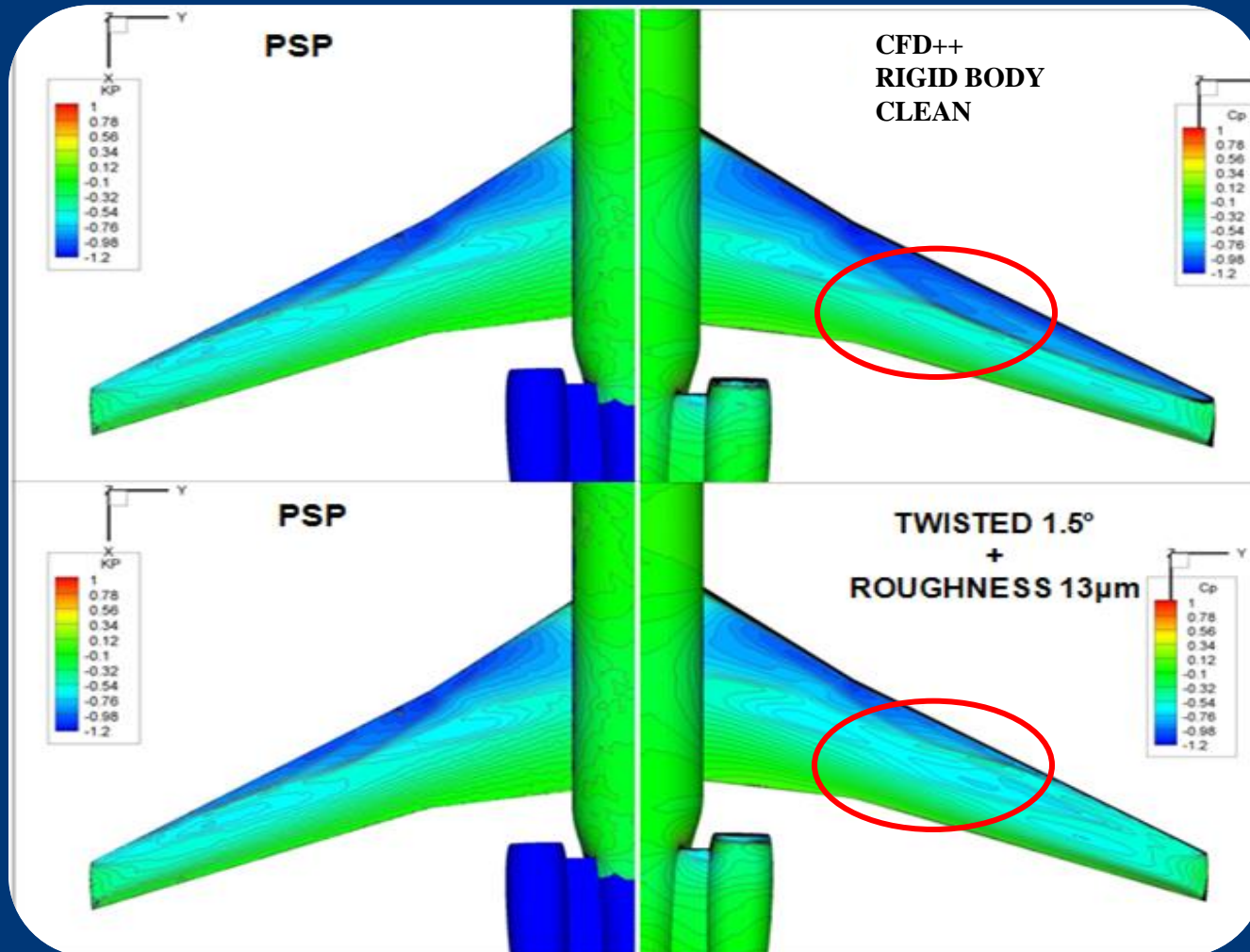

Verifying the qualitative results of that modified simulation on the pressure distribution we obtained a very good agreement in Cp pattern

Next step

Cp distribution on the cut section

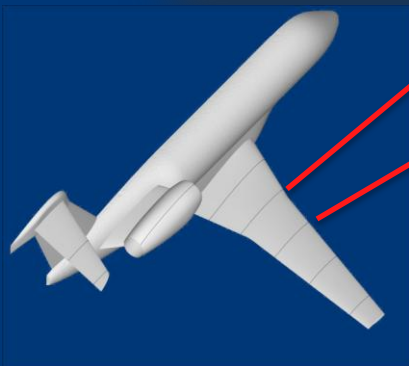
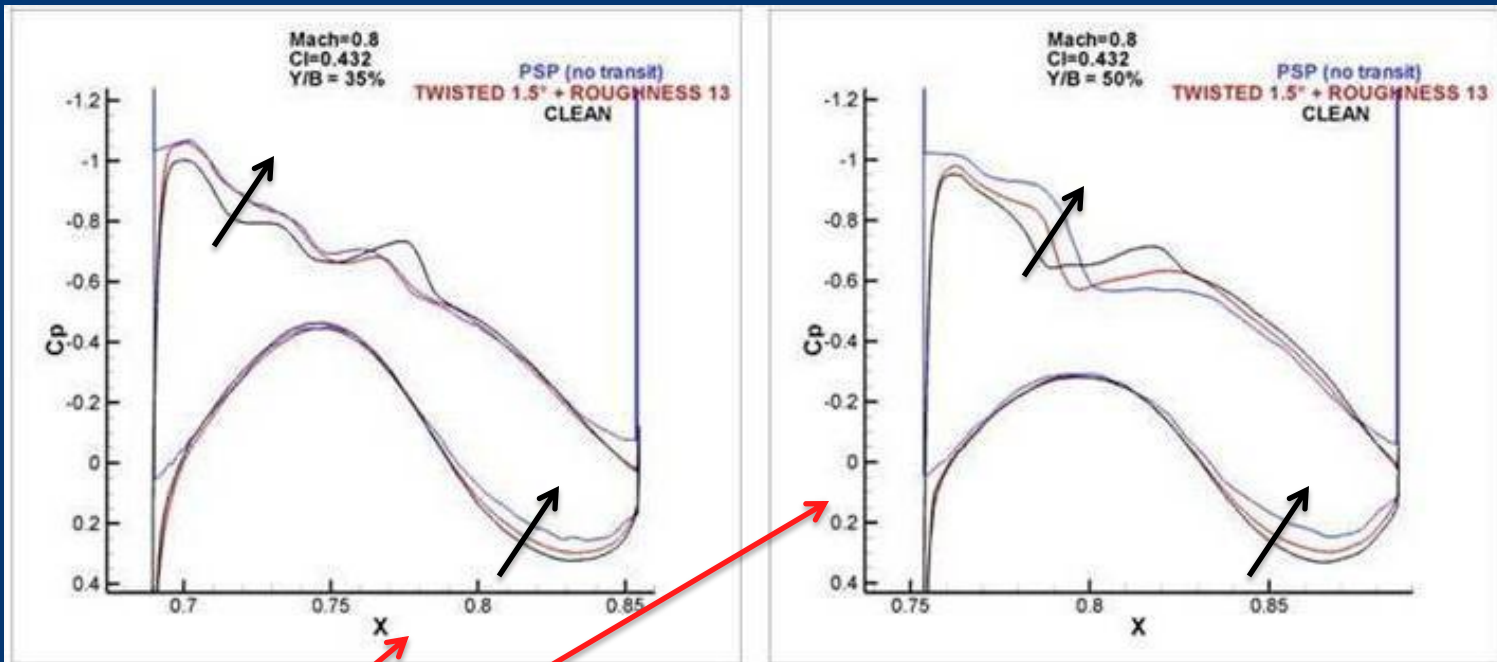

These figures show the benefit of taking in account the combined effect of deformation and roughness but at the same time impose some next steps works to better understand the local differences.

CONCLUSIONS

There are a lot of things that is necessary to keep in mind performing both numerical and experimental campaign. Anyway it's not always possible to predict and prevent some phenomena that are inherent in the nature of the test.

This work is a simple dimostration of the reason why it's still useful to combine CFD and WT investigation.

It's shown here that on the one hand CFD++ may receives a benefit from the WT experience to became a more powerfull design tool and that on the other hand it may be used as a investigation tool for the experimental activity.

Especially in this kind of wind tunnel tests, with similar scaled model with reduced stiffness, is very important to take in account the efficiency reduction due to roughness of the PSP and the lift reduction related to elastic deformation of the structure.

Thank you for your attention!