

Appendix 1

1. Introduction to multiphase flows

Roadmap to Lecture 8

- Turbulence modeling is on top of every type of physics to be simulated, including multiphase flows.
- As in turbulence modeling, when dealing with multiphase flows we can take an approach that resolves all scales, but it is too expensive.
- Therefore, the need of using models.
- And depending on the multiphase system, there are models very specific for the multiphase physics involved.
- Multiphase flows are heavily modeled.

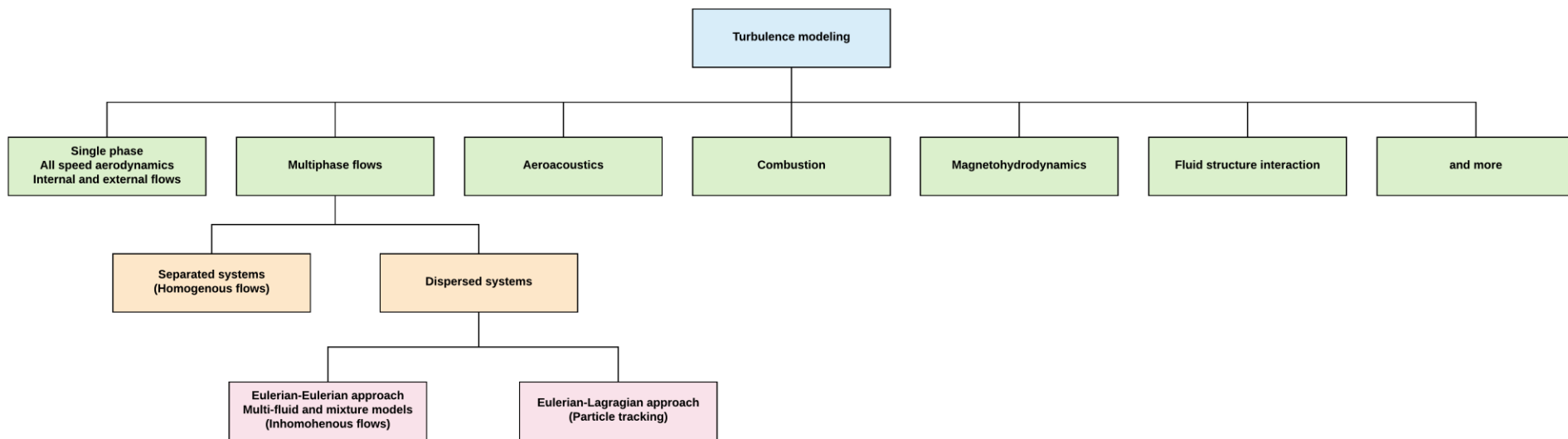

Introduction to multiphase flows

What is a multiphase flow?

- A multiphase flow is a fluid flow consisting of more than one phase component and has some level of phase separation above the molecular level.
- Multiphase flows exist in many different forms. Two phase flows can be classified according to the state of the different phases:
 - Gas-Liquid mixture.
 - Gas-Solid mixture.
 - Liquid-Solid mixture.
 - Immiscible liquid-liquid.



Introduction to multiphase flows

What is a multiphase flow?

- Multiphase flows have some level of phase separation at a scale well above molecular level.
- Multispecies flows have a mixing on the molecular level, there is no interface that indicates a separation at macroscopic level.



Water + oil = multiphase
Clear and distinct interface



Water + tea = multispecies
Molecular mixing, no interface

Introduction to multiphase flows

Multiphase flows in industry and nature based on the state of the different phases

- Multiphase flows are very common in industry and in nature, the following are a few examples depending on the state of the different phase.
- **Gas–particle flows:**
 - Natural: sandstorms, volcanoes, avalanches, rain droplets, mist formation.
 - Biological: aerosols, dust particles, smoke (finely soot particles),
 - Industrial: pneumatic conveyers, dust collectors, fluidized beds, solid propellant rockets, pulverized solid particles, spray drying, spray casting.
- **Liquid–solid flows:**
 - Natural: sediment transport of sand in rivers and sea, soil erosion, mud slides, debris flows, iceberg formation.
 - Biological: blood flow, eyes, lungs.
 - Industrial: slurry transportation, flotation, fluidized beds, water jet cutting, sewage treatment plants, bio-reactors.

Introduction to multiphase flows

Multiphase flows in industry and nature based on the state of the different phases

- **Gas–liquid flows:**
 - Natural: ocean waves.
 - Biological: blood flow, eyes, lungs.
 - Industrial: boiling water and pressurized water nuclear reactors, chemical reactor, desalination systems, sewage treatment plants, boilers, heat exchangers, internal combustion engines, liquid propellant rockets, fire sprinkler suppression systems.
- **Liquid–liquid flows:**
 - Industrial: emulsifiers, fuel-cell systems, micro-channel applications, extraction systems.
- **Gas–liquid–solid flows:**
 - Industrial: air lift pumps, fluidized beds, oil transportation.

Introduction to multiphase flows

Examples of multiphase flows in transportation



Submarine wake

http://commons.wikimedia.org/wiki/File:HMAS_Rankin_2007.jpg#/media/



Cargo ship wake

<http://developeconomies.com/development-economics/how-to-get-america-back-on-track-free-trade-edition/>



High speed boat wake and spray

<http://gizmodo.com/5830571/new-technology-tricks-water-into-thinking-your-ship-isnt-there>

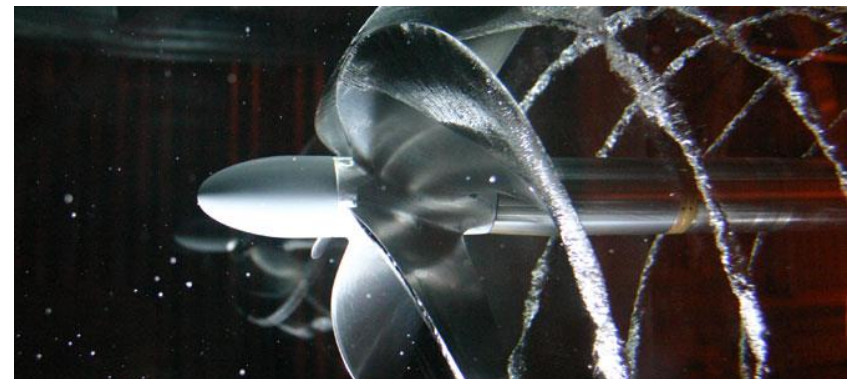

Propeller cavitation

<http://www.veempropellers.com/features/cavitationresistance>

Introduction to multiphase flows

Examples of multiphase flows in nature



Light rain and snowfall

<http://www.esa.int/>



Volcano eruption

<http://americanpreppersnetwork.com/2014/08/preparing-volcano-eruption.html>



Landslide, mudslide, mudflow, debris transport

<http://www.britannica.com/EBchecked/topic/395994/mudflow>



Sand storm

http://www.vizrt.com/news/newsgrid/35339/Sand_storm_potential_forecasts_with_StormGeo__Viz_Weather

Introduction to multiphase flows

Examples of multiphase flows in nature



Siltation & Sedimentation
<http://blackwarriorriver.org/siltation-sedimentation/>



Debris transport
<https://walrus.wr.usgs.gov/elwha/river.html>



Point source pollution – Shipyard
http://commons.wikimedia.org/wiki/File:Jacuecanga_Angra_dos_Reis_Rio_de_Janeiro_Brazil_Brasfels.JPG#/media/File:Jacuecanga_Angra_dos_Reis_Rio_de_Janeiro_Brazil_Brasfels.JPG



Coastal structures – Waves interaction.
http://californiabeachblog.blogspot.it/2013_10_01_archive.html

Introduction to multiphase flows

Examples of multiphase flows for water resources management



Municipal and industrial water treatment

<http://www.asiapacific.basf.com/apex/AP/en/upload/Press2010/BASF-Water-Chem-2010-Paper-Chem-2010-Intex-Shanghai>



Desalinization plant

<http://www.logicom.net/EN/WaterPowerGas/Pages/Desalination.aspx>



Dam spillway

<http://www.abc.net.au/news/2011-10-11/jindabyne-dam-spillway-gates-and-cone-valves-open-rotate840x8/3497340>



Slurry flow

A suspension of solid particles in a liquid, as in a mixture of cement, clay, coal dust, manure, meat, etc. - with water is often called a slurry.
<https://aarondebskibowden.wordpress.com/tag/slurry/>

Introduction to multiphase flows

Multiphase flows in biofuels and bioenergy

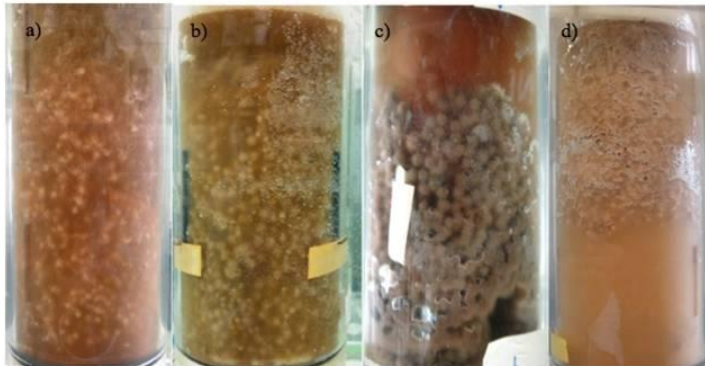

Changes in fungal morphologies during fungal fermentation in airlift reactor at 1.5 vvm: 16 h (a); 24 h (b); 48 h (c); and 72 h (d)

Photo credit: <http://www2.hawaii.edu/~khanal/fungal>



An airlift bioreactor system

Photo credit: <http://www2.hawaii.edu/~khanal/fungal>



Ethanol fermentation for vinasse preparation (a) and vinasse (b)

Photo credit: <http://www2.hawaii.edu/~khanal/fungal>



Moss bioreactor– University Freiburg

Photo credit: http://commons.wikimedia.org/wiki/File:Bioreaktor_quer2.jpg#/media/File:Bioreaktor_quer2.jpg

Introduction to multiphase flows

Multiphase flows in energy generation



Cooling Towers

<https://whatiswatertreatment.wordpress.com/what-are-the-systems-associated-with-water-treatment-and-how-are-they-treated/103-2/>



Fuel cells

<http://www.h2fc-fair.com/hm12/highlights.html>



A bus fueled by biodiesel

<http://commons.wikimedia.org/wiki/File:Soybeanbus.jpg#/media/File:Soybeanbus.jpg>

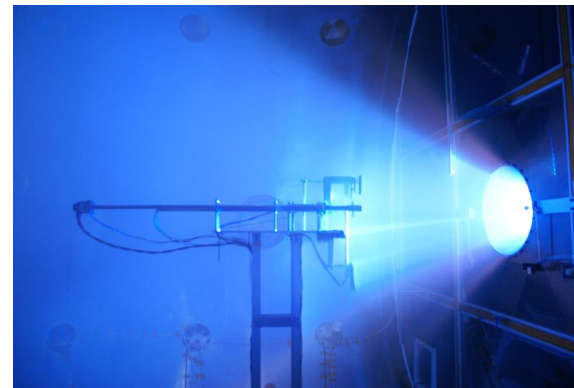

Plasma engine

http://en.wikipedia.org/wiki/File:VX-200_operation_full_power.jpg#/media/File:VX-200_operation_full_power.jpg

Introduction to multiphase flows

Multiphase flows – Food processing



Grain/rice/Wheat/Seed hopper – Controlled atmosphere storage using carbon dioxide

<http://www.co2meter.com/blogs/news/6077164-controlled-atmosphere-storage-using-carbon-dioxide>



Fermentation of beer and spirits

<http://www.distillingliquor.com/2015/02/05/how-to-make-alcohol-and-spirits/>



Machine used for drying the coffee beans

<https://www.travelblog.org/Photos/4865694>

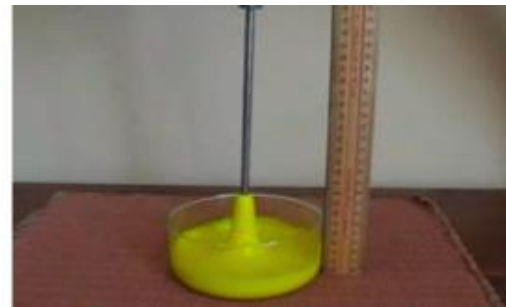

Visco-elastic fluids – Weissenberg effect. Dough tend to climb up rotating shafts

<https://raweb.inria.fr/rapportsactivite/RA2010/concha/uid20.html>

Introduction to multiphase flows

Multiphase flows in bubble columns

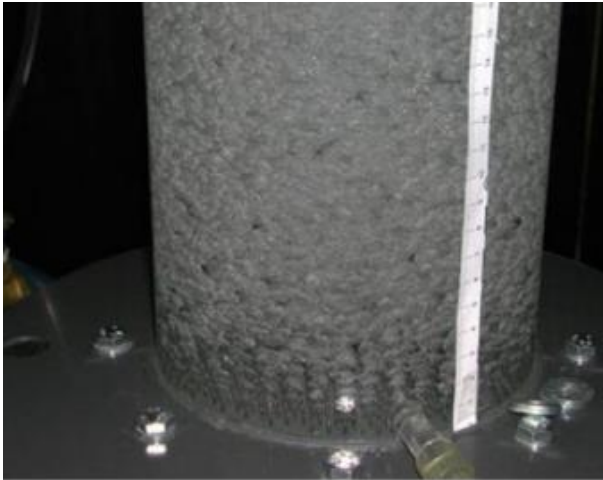

3-D bubble column

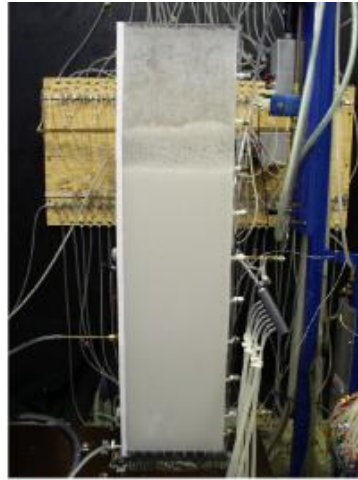

2-D column

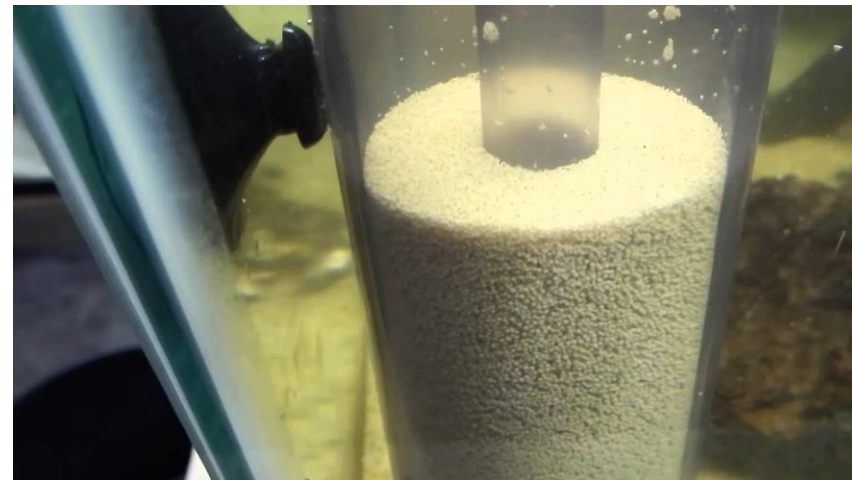

Fluidized bed filter

Photo credit: <https://www.youtube.com/watch?v=fPnr4ZsoJwE>
Copyright on the images is held by the contributors. Apart from Fair Use, permission must be sought for any other purpose

Bubble columns

Photo credit: <http://www.cheme.nl/tp/people/hooshyar.shtml>
Copyright on the images is held by the contributors. Apart from Fair Use, permission must be sought for any other purpose



Fluidized bed drying

Photo credit: <https://www.glatt.com/en/processes/fluidized-bed-drying/>
Copyright on the images is held by the contributors. Apart from Fair Use, permission must be sought for any other purpose

Introduction to multiphase flows

Multiphase flows – Additional applications



Molten iron

<http://www.castingsolutions.com/production>



Nozzle spray

<http://www.cdtextbook.com/asearticles/quietdieseevol.html>



Chemical reactor for the pharmaceutical and biotechnology industry

<http://www.total-mechanical.com/Industrial/CaseStudies.aspx>



Pipelines

http://www.downstreamtoday.com/%28S%282cugvw45vzs5a04541d1e4jy%29%29/new/s/article.aspx?a_id=18931&AspxAutoDetectCookieSupport=1

Introduction to multiphase flows

Multiphase flows – Additional applications



Hydrophobic and Oleophobic coatings textiles

<http://www.aculon.com/industrial.php>

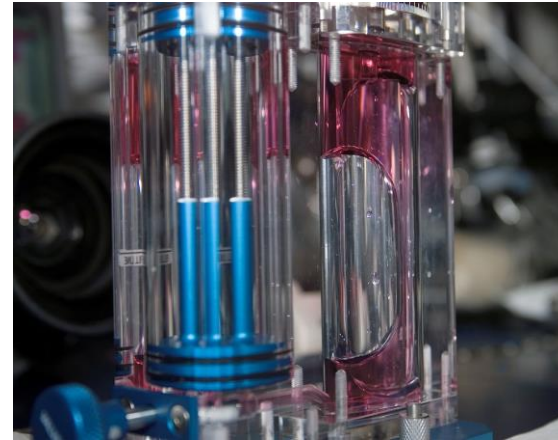

Capillary flows

http://commons.wikimedia.org/wiki/File:Capillary_Flow_Experiment.jpg#/media/File:Capillary_Flow_Experiment.jpg

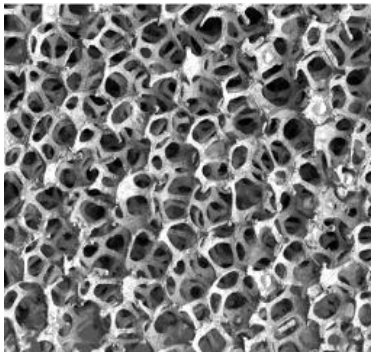

Porous media for air filter and noise reduction

<https://www.newcastle.edu.au/research-and-innovation/centre/cgmm/research/thermal-transport-in-composites-and-porous-media>



Oil well drilling and water injection

https://www.osha.gov/SLTC/etools/oilandgas/servicing/special_services.html

Introduction to multiphase flows

- **As you can see, multiphase flows are present in many industrial processes and natural systems.**
- **Hence the importance of understanding, modeling, and simulating multiphase flows.**

Introduction to multiphase flows

Classifying multiphase flow according to phase morphology

- **Disperse phase:** the phase is dispersed as non-contiguous isolated regions within the other phase (the continuous phase) . When we work with a disperse phase we say that the system is dispersed: disperse-continuous flow.
- **Continuous phase:** the phase is contiguous throughout the domain and there is one well defined interphase with the other phase. When we work with continuous phases we say that the system is separated: continuous-continuous flow.



Dispersed system



Separated system

Introduction to multiphase flows

Multiphase flow regimes

- Flow maps and flow patterns in horizontal pipes

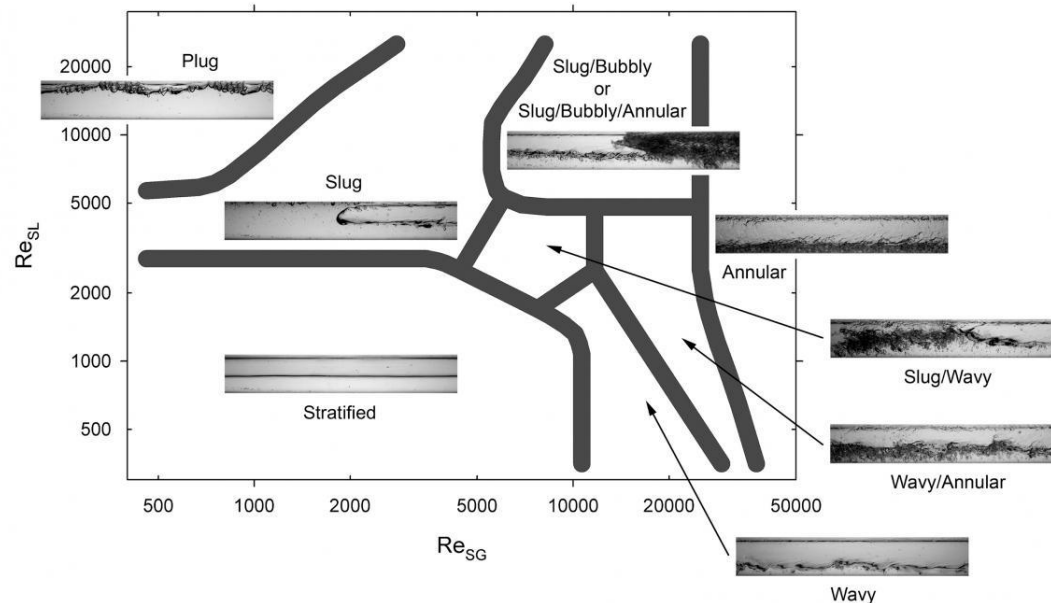
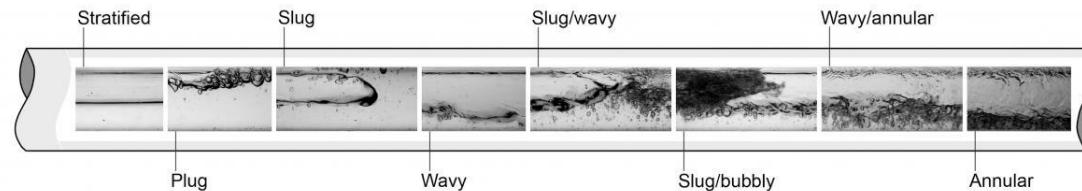

Introduction to multiphase flows

Multiphase flow regimes

- Flow maps and flow patterns in vertical pipes (upward flow)

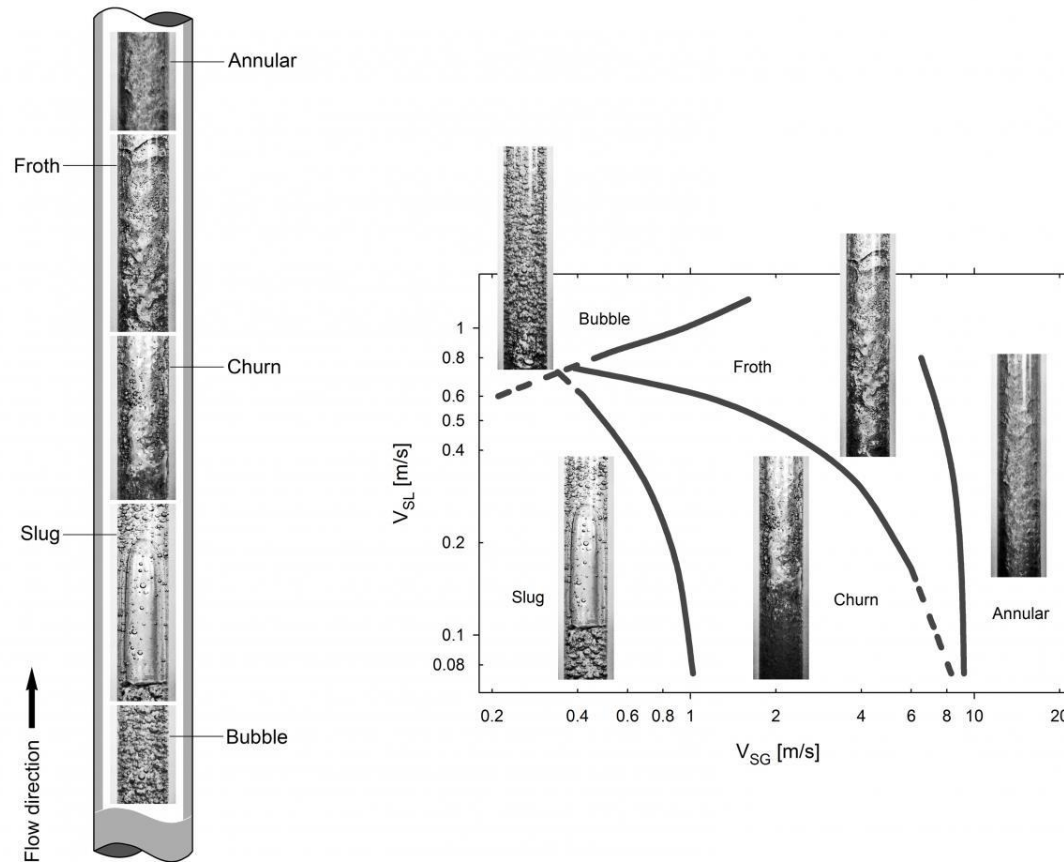

Introduction to multiphase flows

Multiphase flow regimes

- Flow maps and flow patterns in vertical pipes (downward flow)

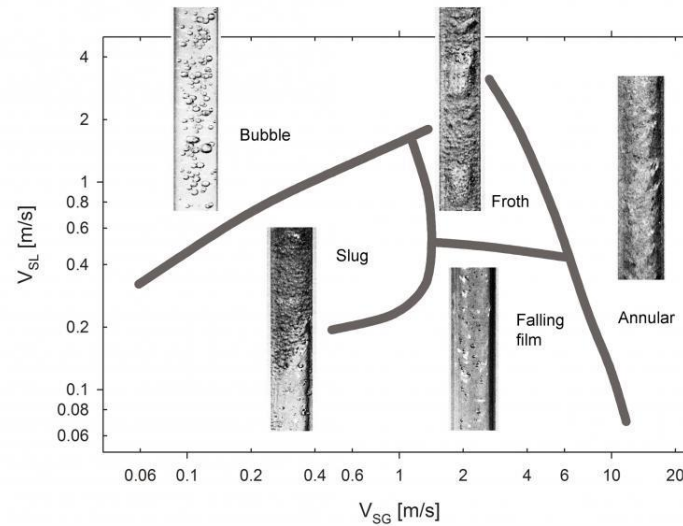
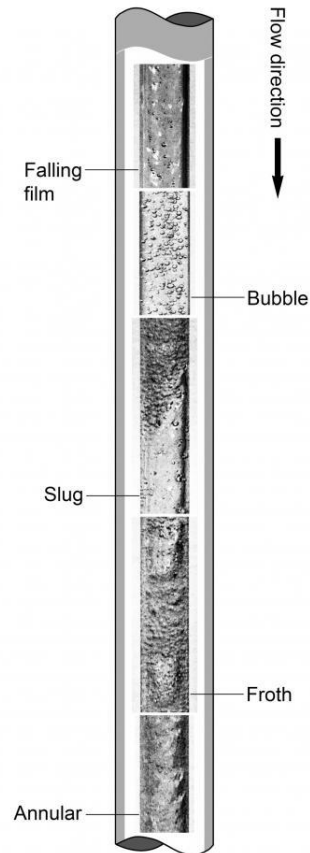

Introduction to multiphase flows

Multiphase flow regimes

- Flow regimes in fluidized beds (solid-gas)

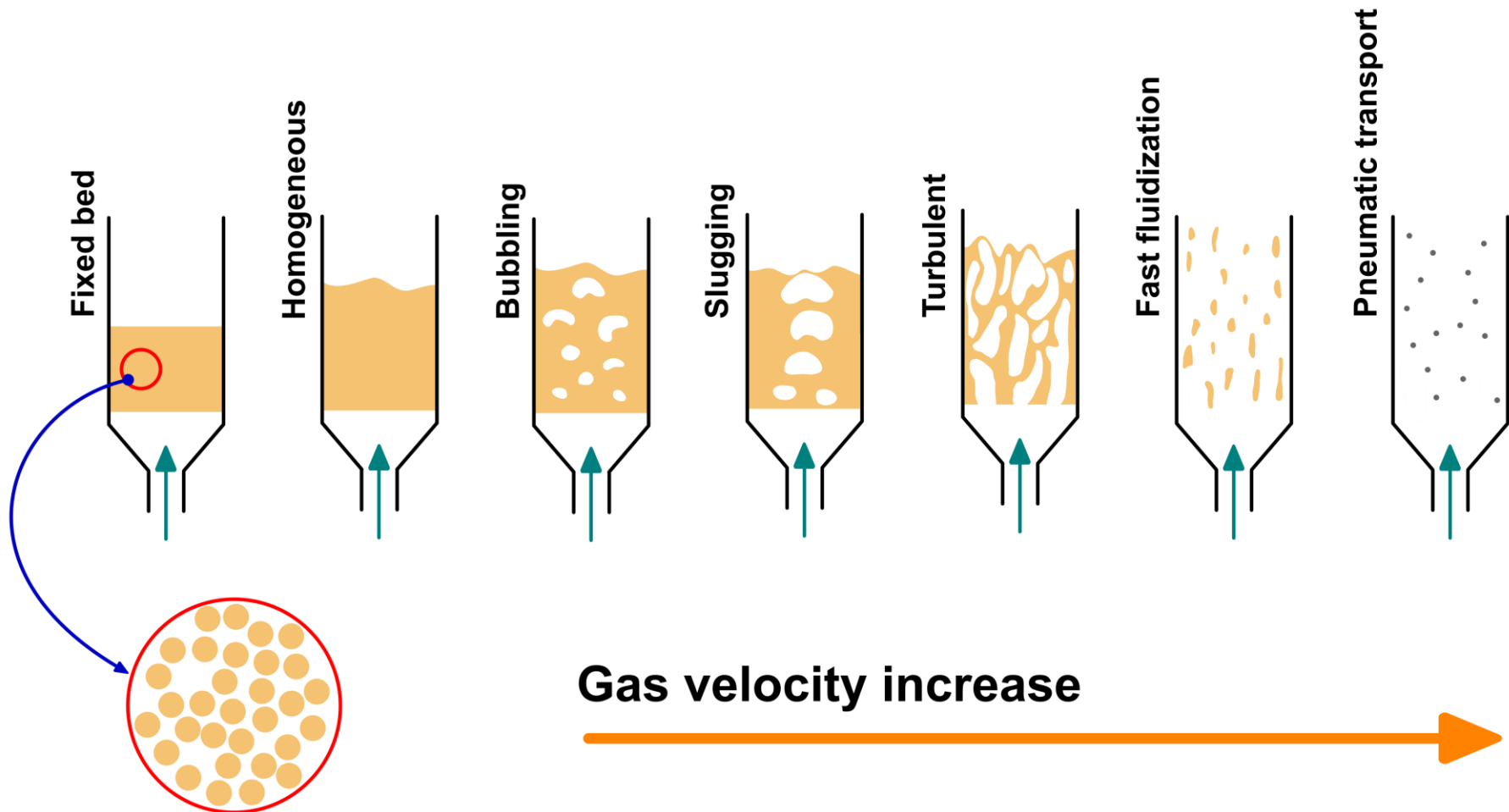

Introduction to multiphase flows

Multiphase flow videos



3D dam-break simulation

Comparison of numerical results obtained with OpenFOAM-4.x using a multiphase solver, against the experimental results obtained by the Maritime Research Institute Netherlands (MARIN).

Useful references:

<http://app.spheric-sph.org/sites/spheric/tests/test-2>

<http://www.wolfdynamics.com/tutorials.html?id=95>

<http://www.wolfdynamics.com/training/mphase/dbreak.mp4>

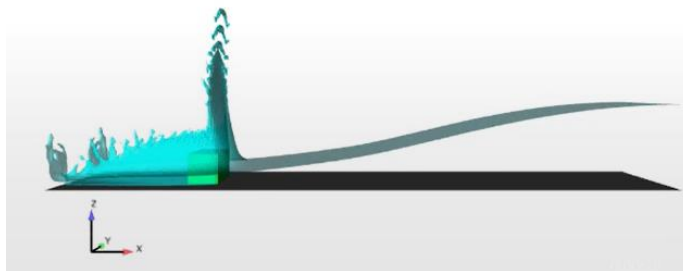

A Volume-of-Fluid Based Simulation Method for Wave Impact Problems. *Journal of Computational Physics* 206(1):363-393. June, 2005.

Open link to videos 

Introduction to multiphase flows

Multiphase flow videos

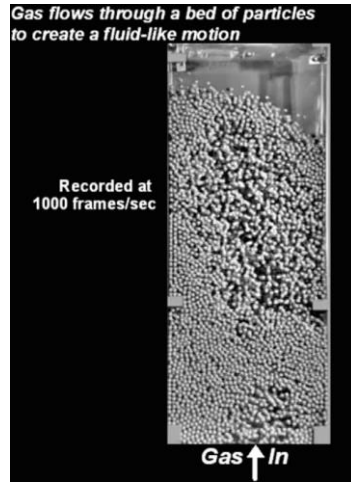

2013 GFM, Video 064: The Science and Beauty of Fluidization: High Speed Imaging of Particle Flow Fields

Authors: Frank Shaffer and Balaji Gopalan

DOE National Energy Technology Laboratory (USA)

http://www.wolfdynamics.com/training/mphase/2013_GFM_Video_064.mp4



2013 GFM, Video 054: Hydrodynamics Causes and Effects of Air Bubbles Rising in Very Viscous Media

Authors: Sharad Chand Ravinuthala

Department of Mechanical Engineering, West Virginia University (USA)

http://www.wolfdynamics.com/training/mphase/2013_GFM_Video_054.mp4

Open link to videos 

Introduction to multiphase flows

Multiphase flows simulations

**Simulation of gravity current – Onset of Kelvin-Helmholtz instability
Liquid-liquid interaction (VOF)**

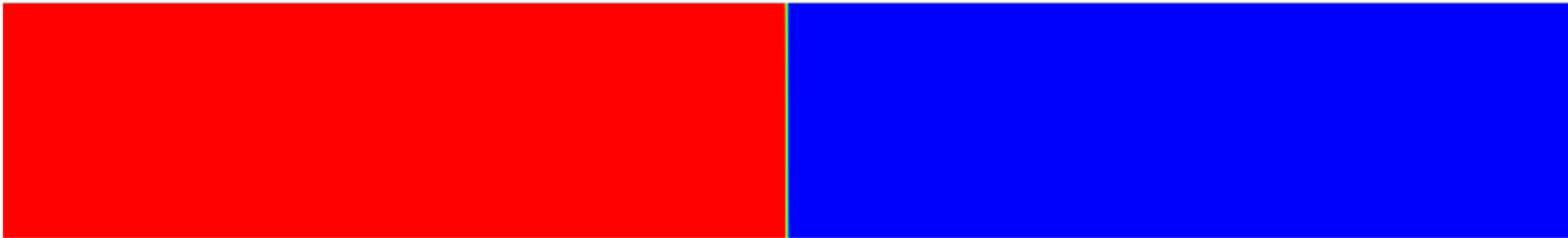

Introduction to multiphase flows

Multiphase flows simulations

Onset of Kelvin-Helmholtz instability – Liquid-liquid interaction (VOF)

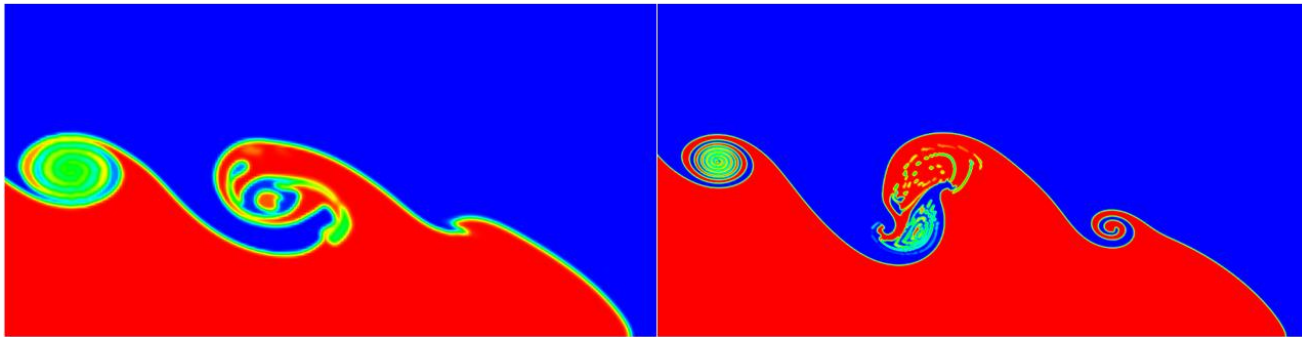

Medium grid size

Extra-fine grid size

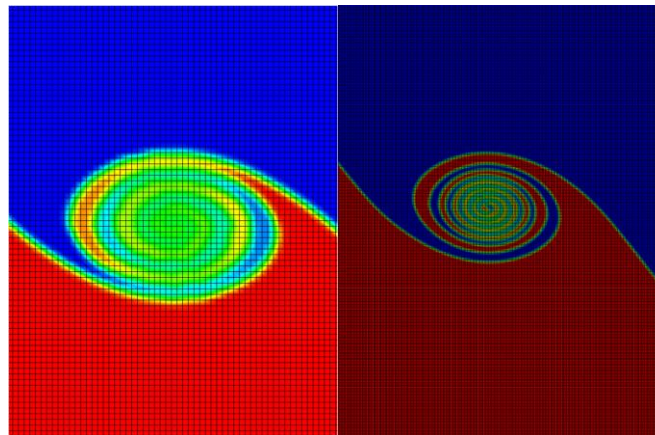

Medium grid size

Extra-fine grid size

Introduction to multiphase flows

Multiphase flows simulations

Three rising bubbles (VOF with AMR)



Time: 0.00

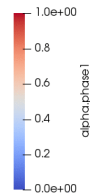

Time: 0.00

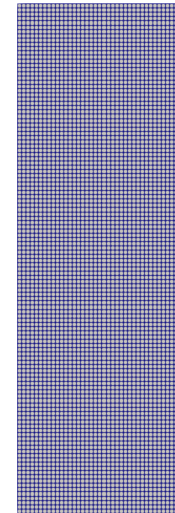

<http://www.wolfdynamics.com/training/mphase/image2.gif>

<http://www.wolfdynamics.com/training/mphase/image3.gif>

Introduction to multiphase flows

Multiphase flows simulations

Rayleigh-Taylor instability – Liquid-liquid-liquid interaction
(VOF with 3 phases)



Time: 0.000000

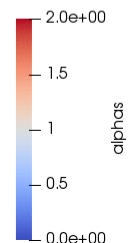

Introduction to multiphase flows

Multiphase flows simulations

Particle interaction (no hydrodynamic coupling)



Time: 0.002000

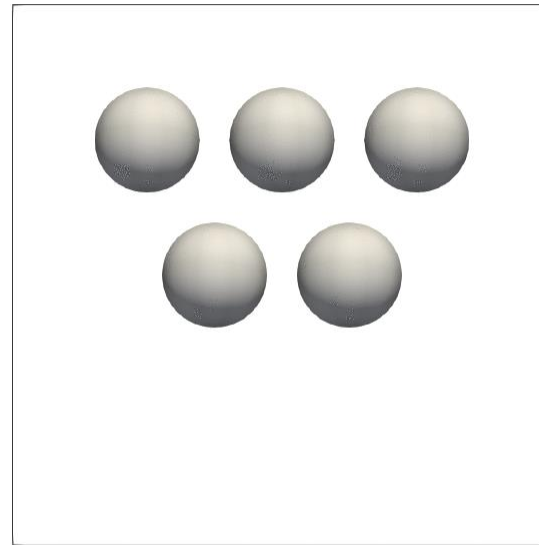

Introduction to multiphase flows

Multiphase flows simulations

Fluidized bed hydrodynamics – Gas-solid interaction with hydrodynamic coupling



Time: 0.01

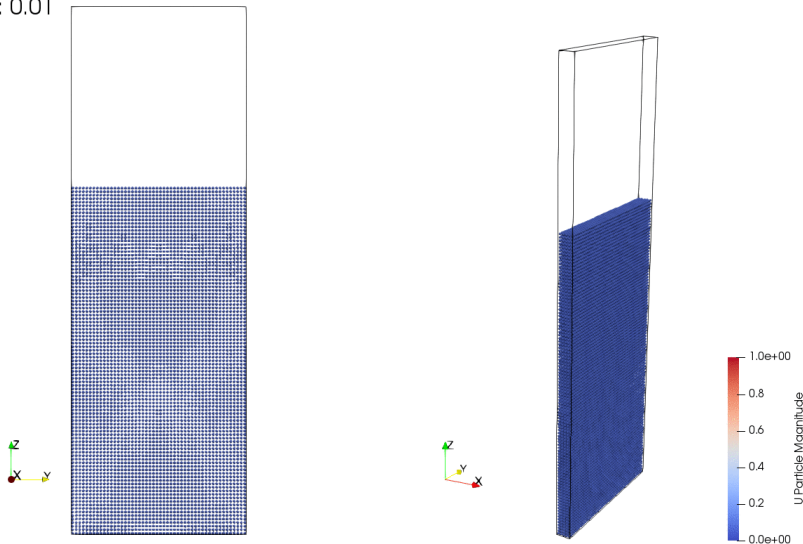

Particles interaction

Time: 0.00

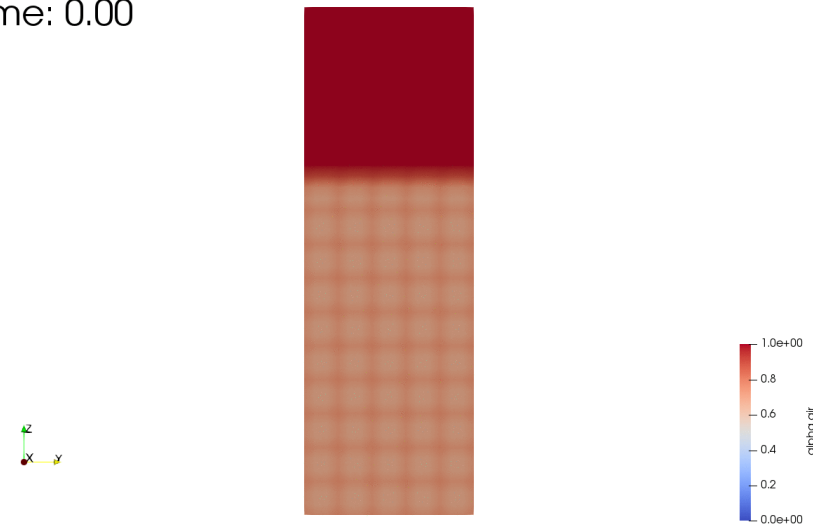

VOF air

Introduction to multiphase flows

Multiphase flows simulations

Continuous stirring tank reactor (CSTR)

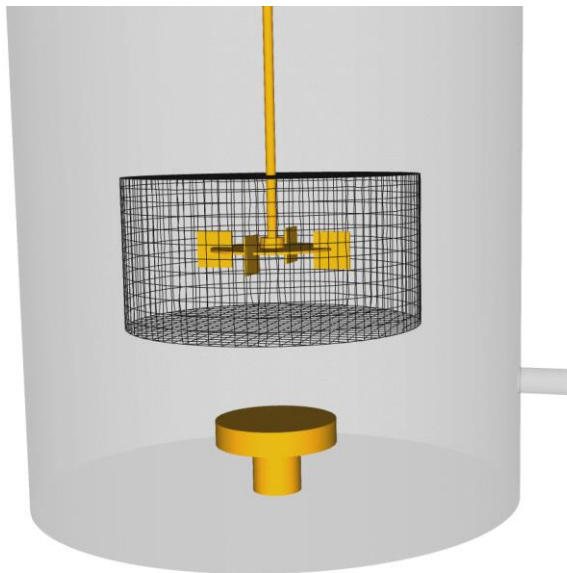

Time: 0.020

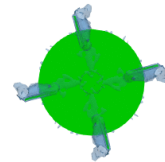
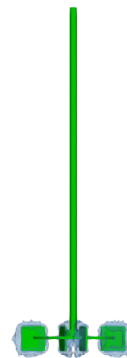

www.wolfdynamics.com/training/mphase/image8.gif

<http://www.wolfdynamics.com/training/movingbodies/image13.gif>

Introduction to multiphase flows

Multiphase flows simulations

Dynamics of gas-liquid flow in a reactor tank (Euler-Euler)

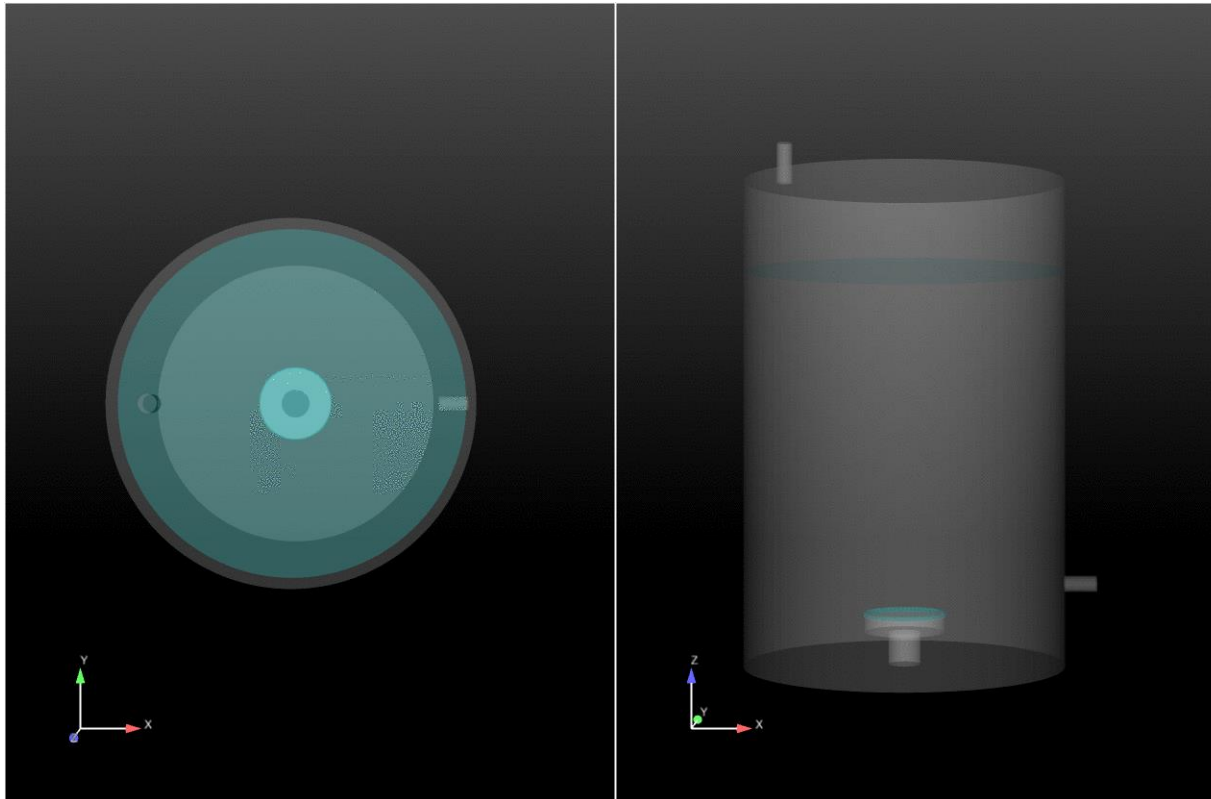

Introduction to multiphase flows

Multiphase flows simulations

Free surface – Sea keeping (VOF)

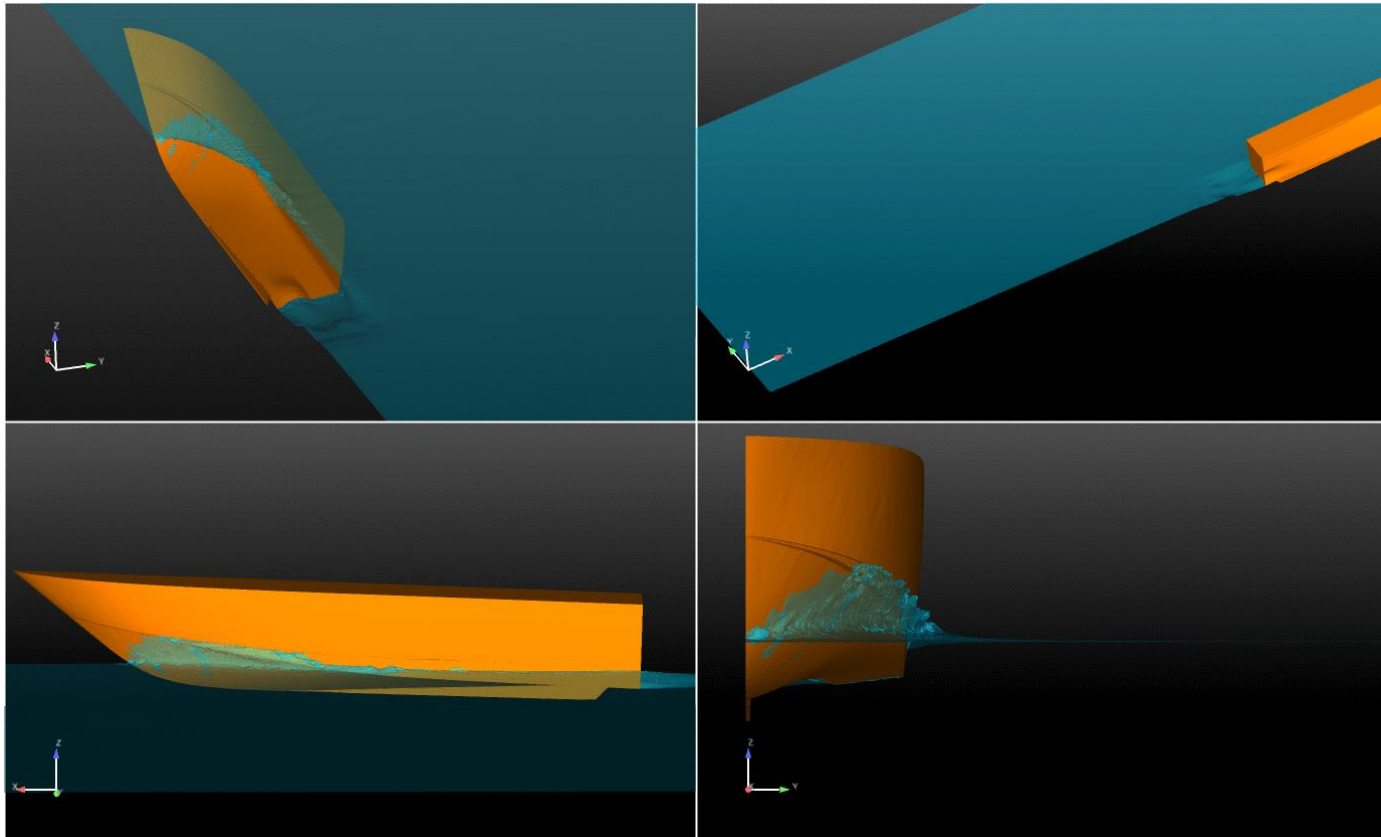

Introduction to multiphase flows

Multiphase flows simulations

Free surface – Water splash (VOF)

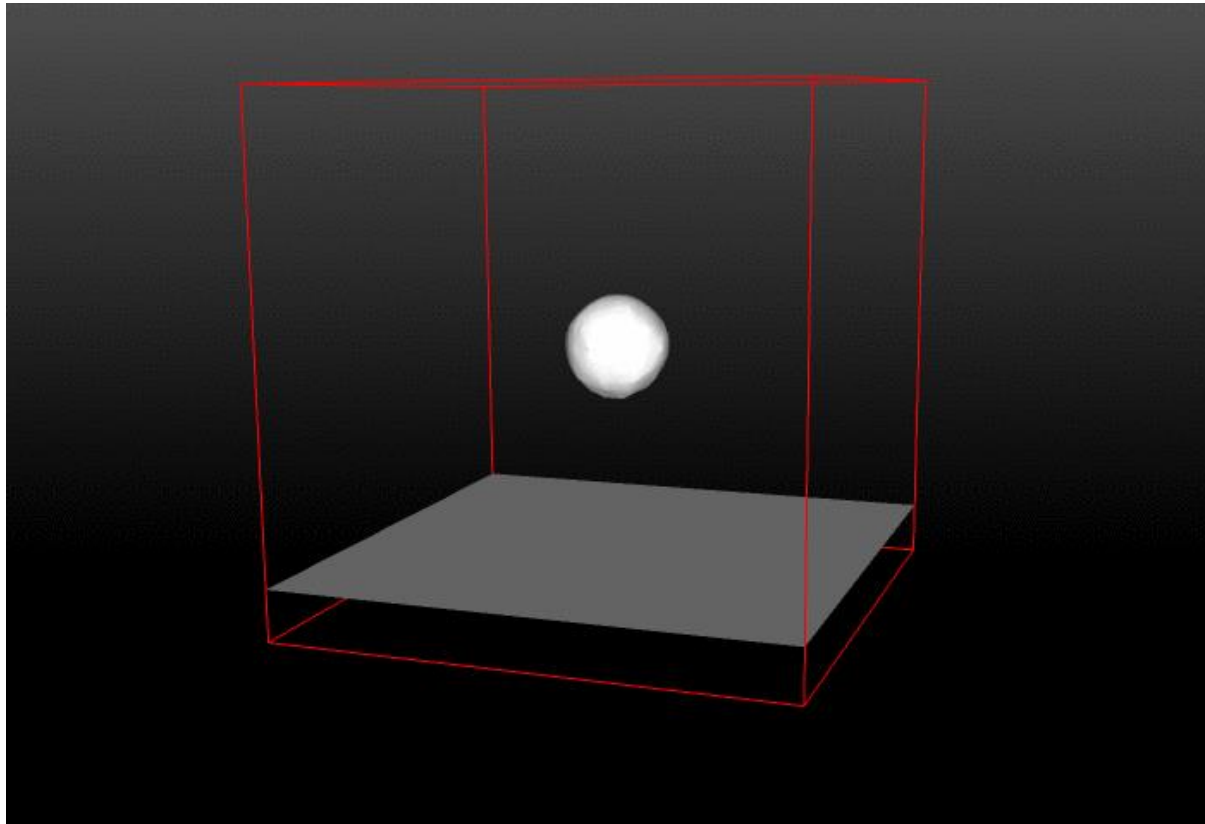

Introduction to multiphase flows

Multiphase flows simulations

Surface film (Euler-Euler plus wall film)

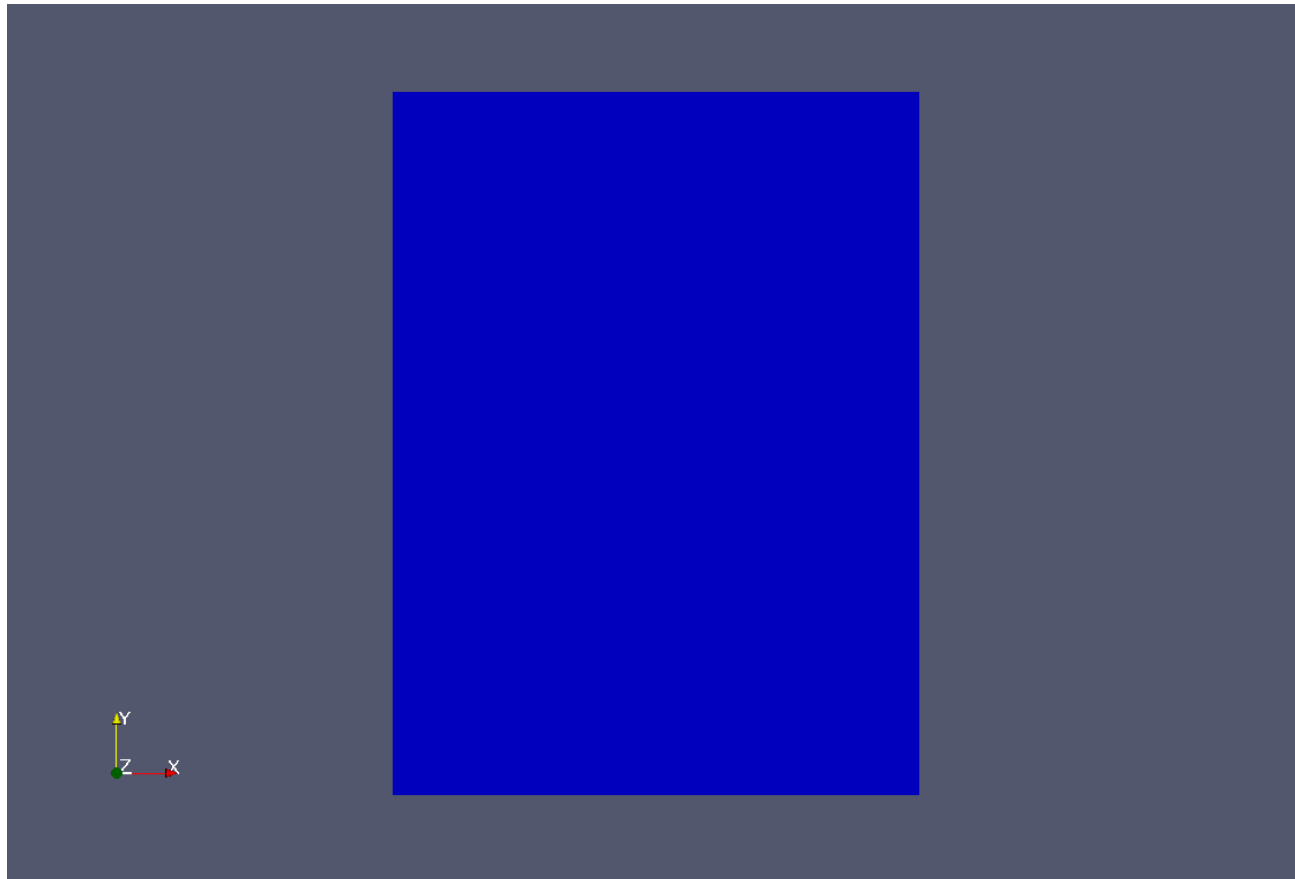

Introduction to multiphase flows

Multiphase flows simulations

Density current with pollutant transport – 8 phases (Euler-Euler)

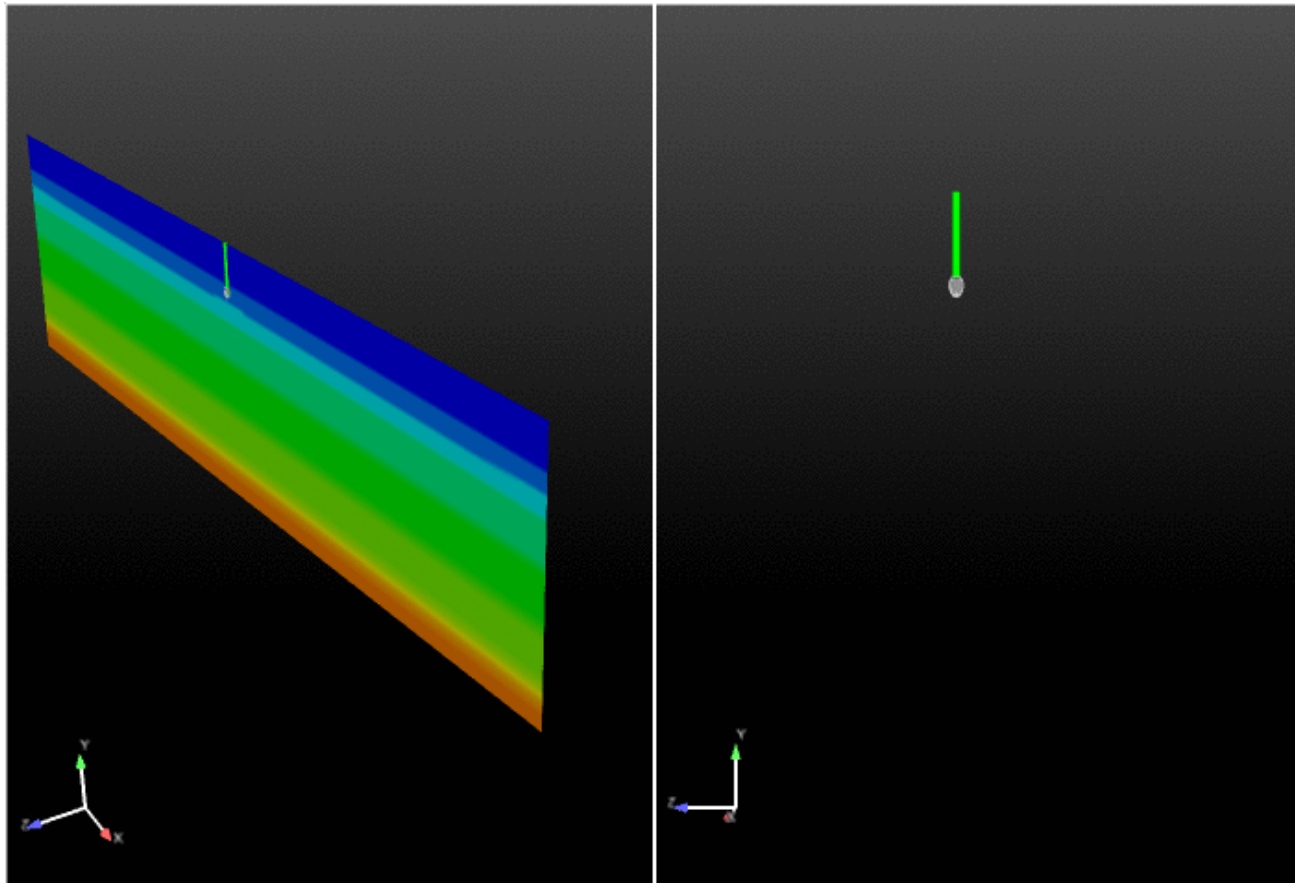

Introduction to multiphase flows

Multiphase flows simulations

Capillary effect – VOF with contact angle



Time: 0.000000

Time: 0.000000

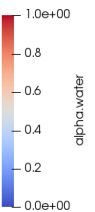
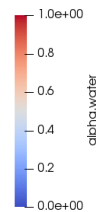

interFoam with contact angle 10 (hydrophilic surface)

<http://www.wolfdynamics.com/training/mphase/image28.gif>

interFoam with contact angle 135 (hydrophobic surface)

<http://www.wolfdynamics.com/training/mphase/image29.gif>

Introduction to multiphase flows

Multiphase flows simulations

Surface tension effect in zero gravity

Time: 0.000000

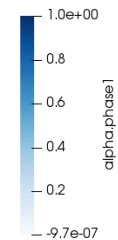

<http://www.wolfynamics.com/training/mphase/image37.gif>

Introduction to multiphase flows

Multiphase flows simulations

Sphere in a towing tank – VOF with Free surface

Time: 0.000000

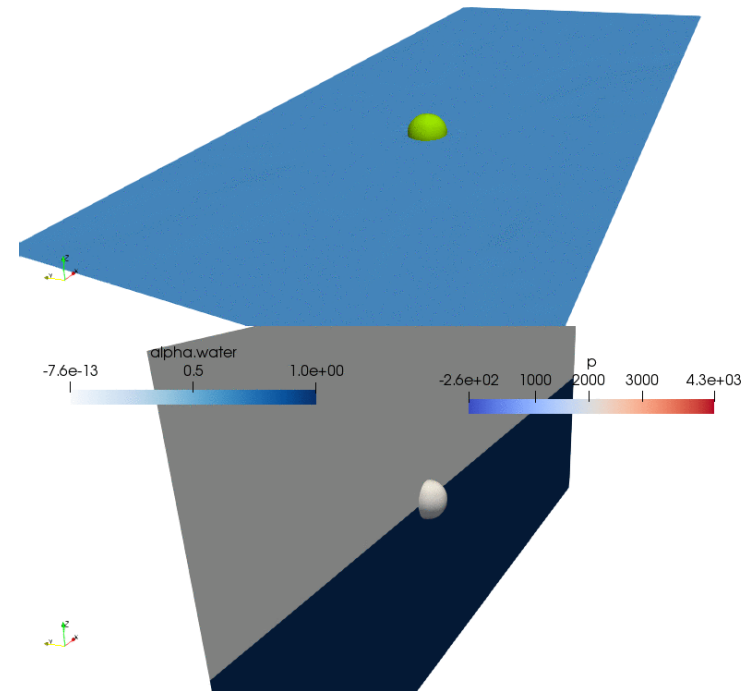
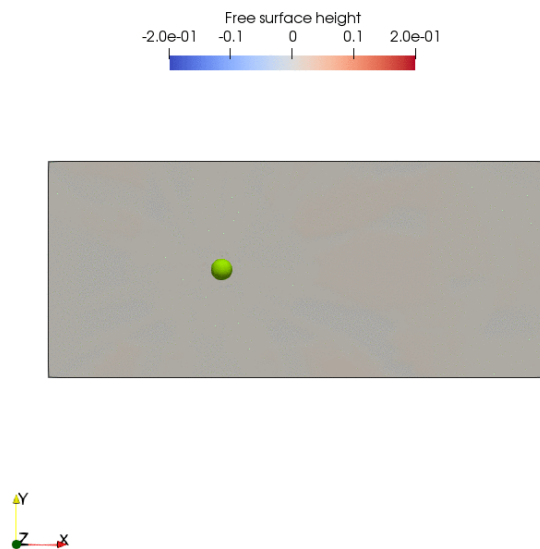

<http://www.wolfdynamics.com/training/mphase/image15.gif>

Introduction to multiphase flows

Multiphase flows simulations

MRF vs. Sliding grids – VOF



Time: 0.020

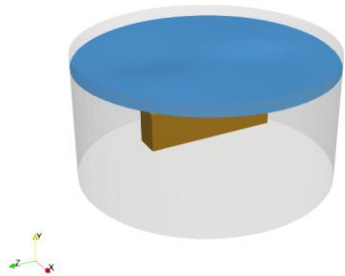

MRF

<http://www.wolfynamics.com/training/mphase/MRF1.gif>



Time: 0.020

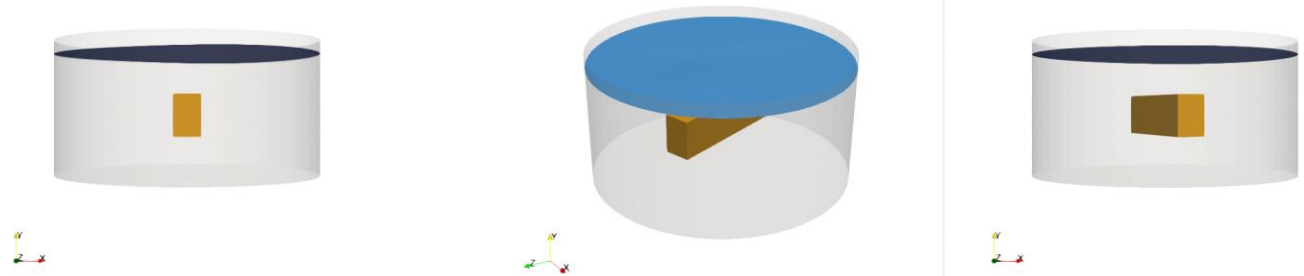

Dynamic meshes

<http://www.wolfynamics.com/training/mphase/sliding1.gif>

Introduction to multiphase flows

Multiphase flows simulations

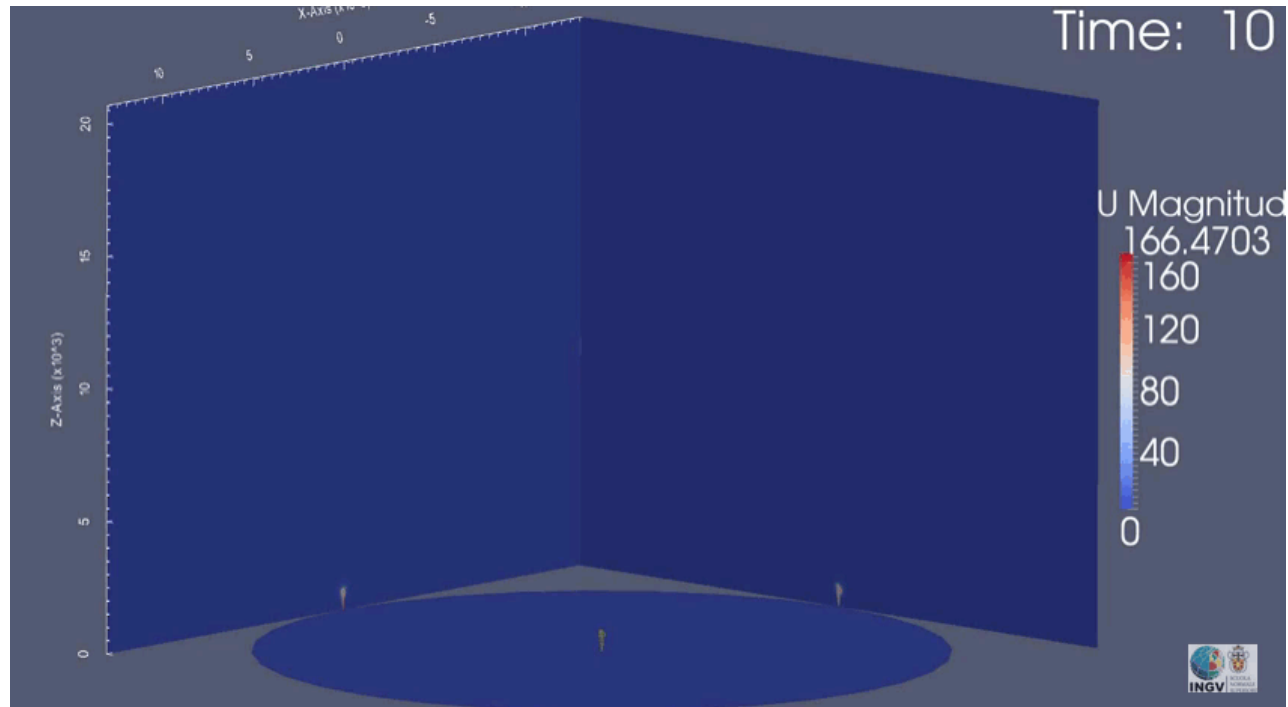

www.wolfdynamics.com/training/mphase/image14.gif

Disperse Multiphase Turbulence with OpenFOAM

Gas-particle decoupling in volcanic plumes and density currents

Simulation of a volcanic weak Plume with the dusty-gas (pseudo-gas) model with ash, H₂O inside the stratified atmosphere.

Introduction to multiphase flows

Multiphase flows simulations

Wave impact in a column

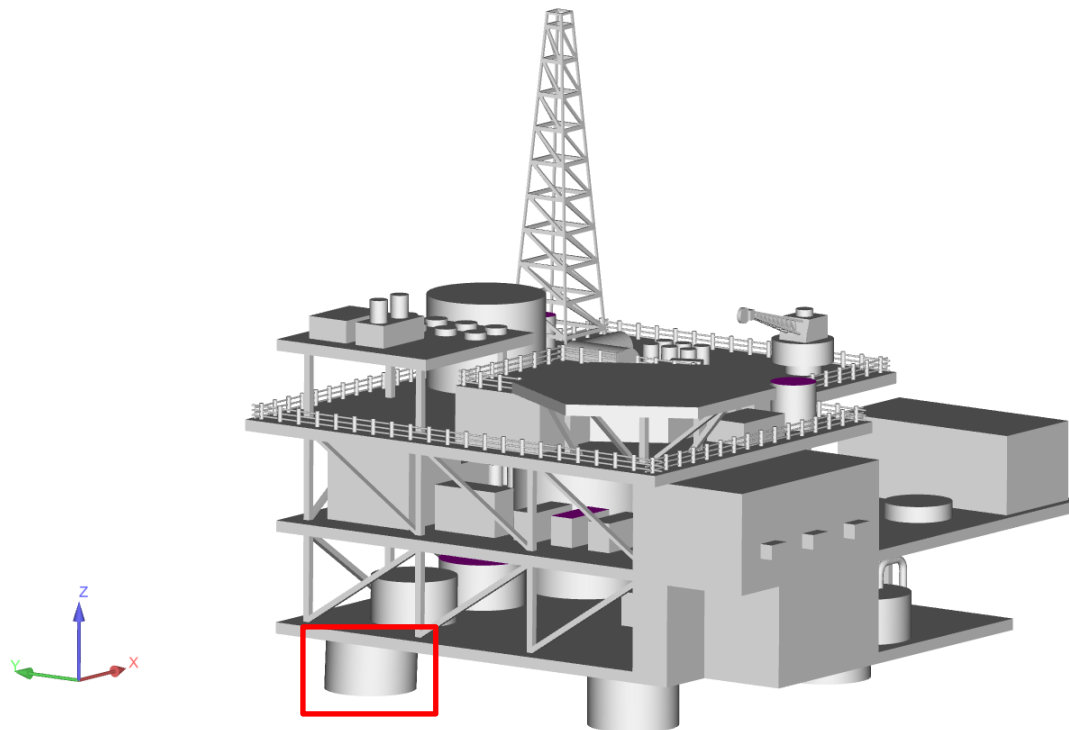

- This is the big picture.
- For this case we are going to simulate only one support column (the column in the red square).

Introduction to multiphase flows

Multiphase flows simulations

Wave impact in a column

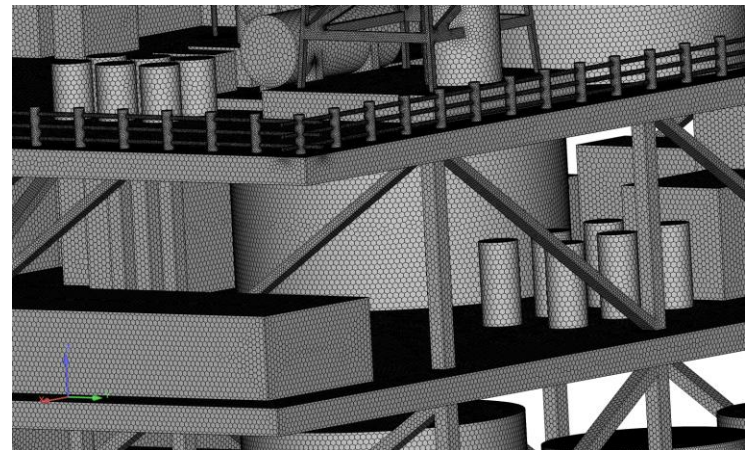
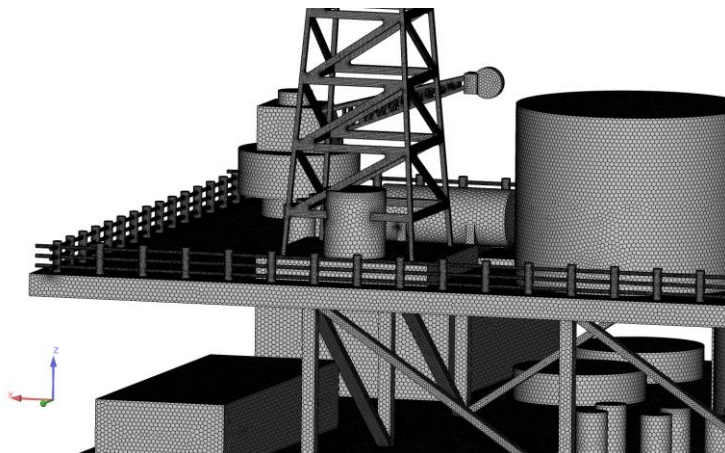
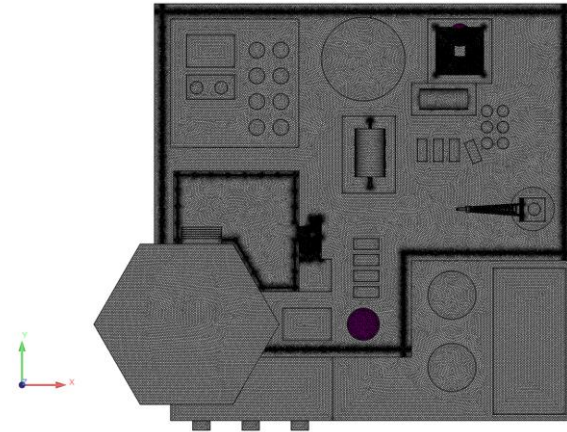
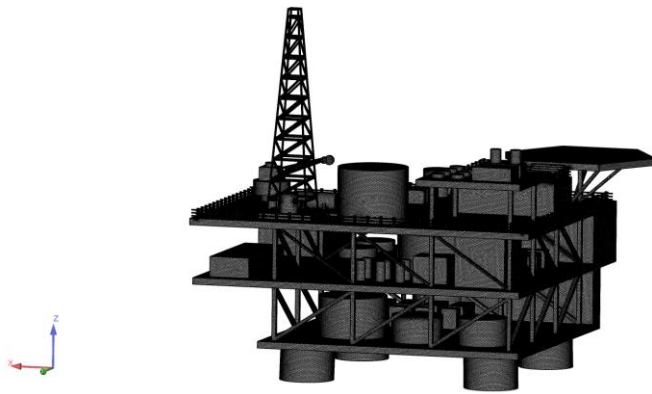

Introduction to multiphase flows

Multiphase flows simulations

Wave impact in a column

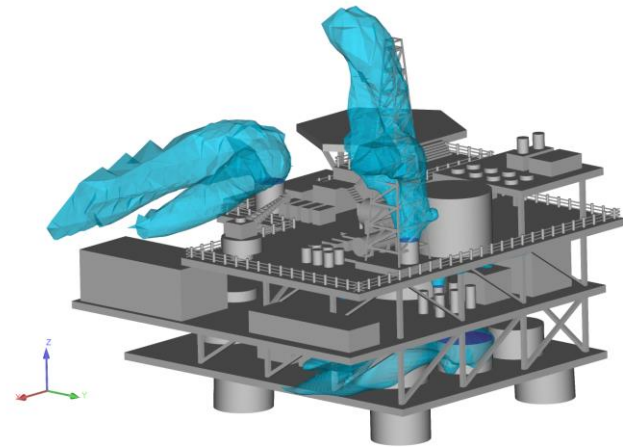
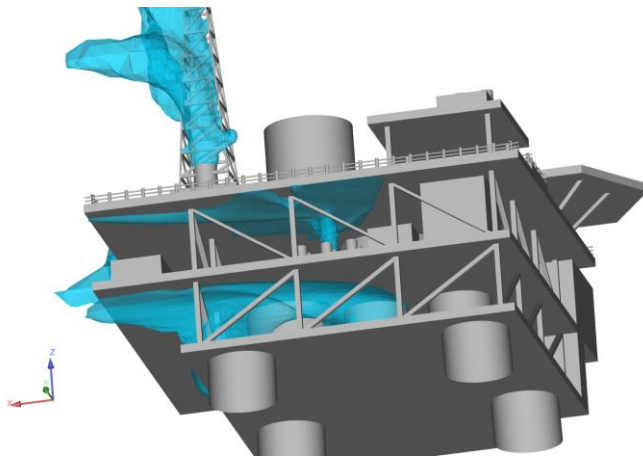
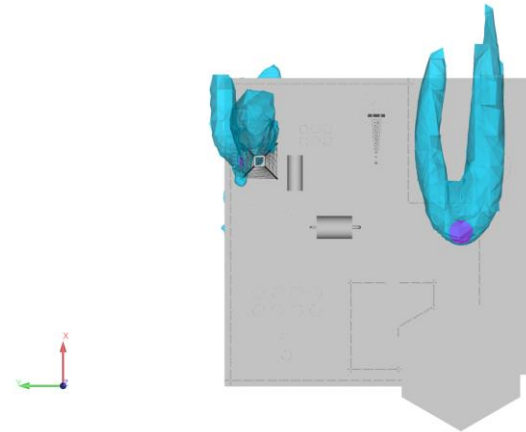
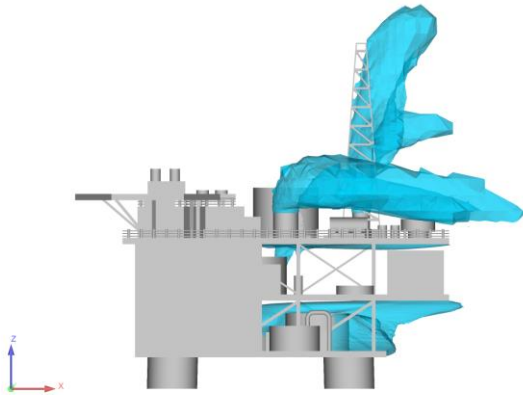

Introduction to multiphase flows

Multiphase flows simulations

Wave impact in a column

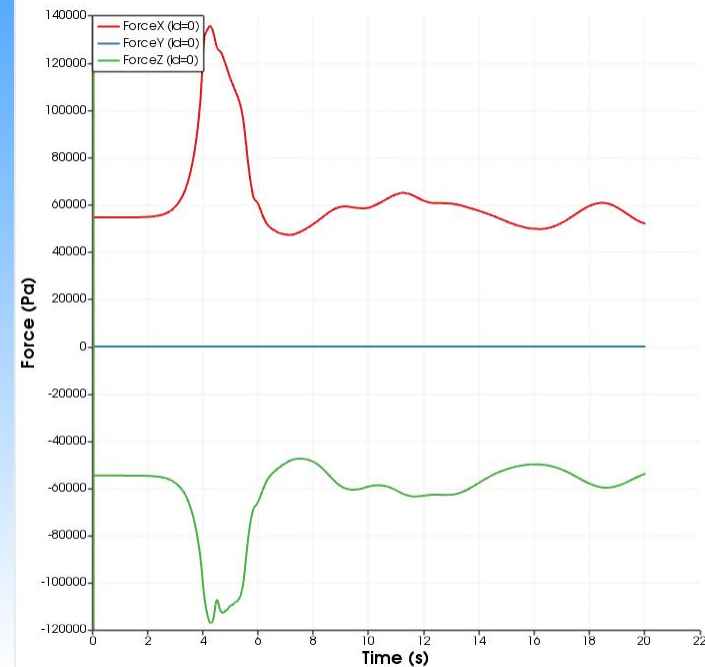
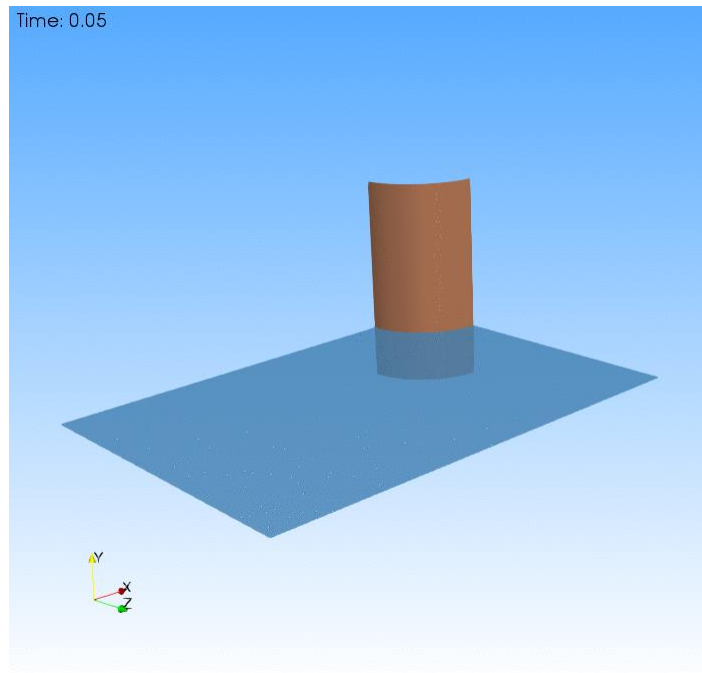

Hexahedral mesh.

Left figure: free surface interaction with solid structure. Right figure: forces acting on the column.

<http://www.wolfdynamics.com/training/mphase/gt1/hexa/ani2.gif>

Introduction to multiphase flows

Multiphase flows simulations

Wave impact in a column

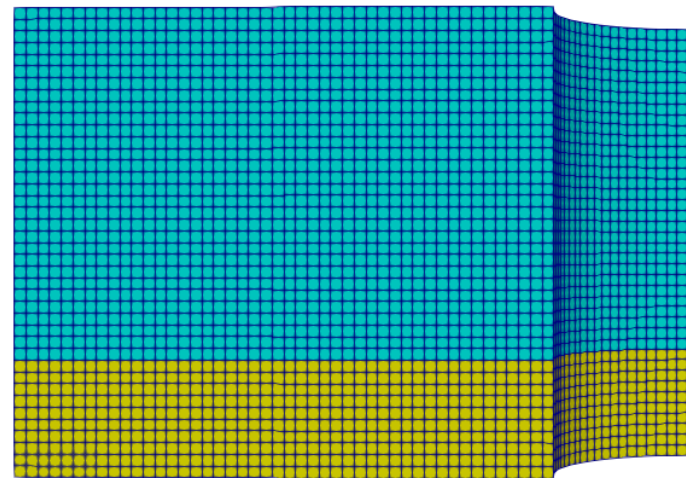
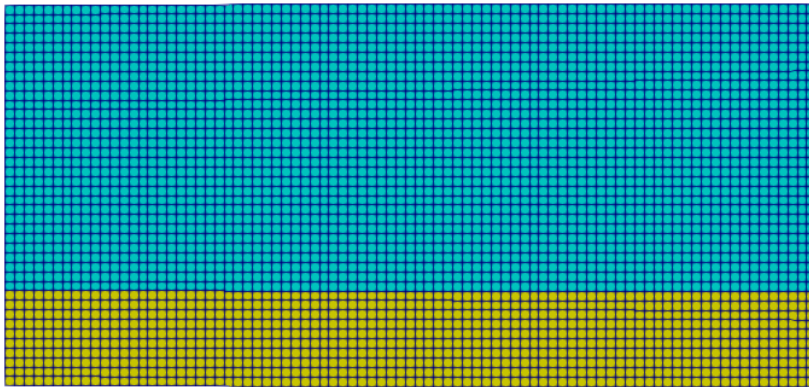

- When conducting free surface simulations, it is extremely important to generate a mesh that is aligned with the free surface level (at least at the free surface level).
- If the cells are not aligned, this may introduce spurious oscillations which might or might not be significant.
- In this case, the hexahedral cells are aligned with the free surface.
 - The quality of the solution at the free surface is much better than the solution with the polyhedral mesh.
 - Also, the error associated with this mesh is much lower than the error associated with the polyhedral mesh.

Introduction to multiphase flows

Multiphase flows simulations

Wave impact in a column

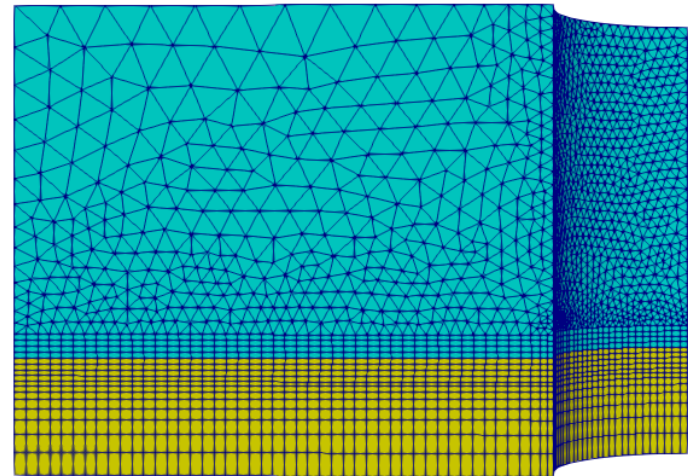
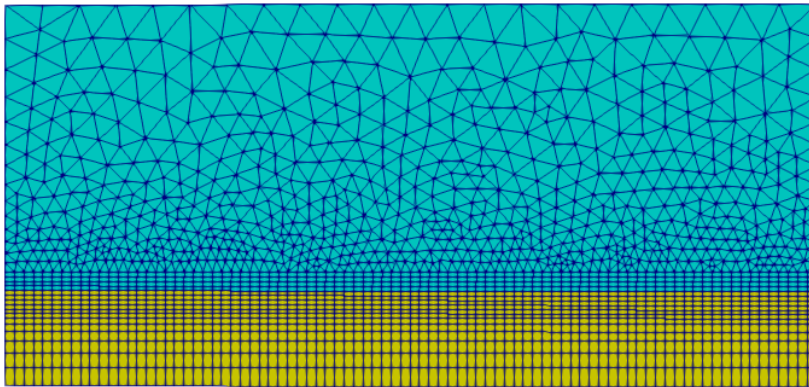

- When conducting free surface simulations, it is extremely important to generate a mesh that is aligned with the free surface level (at least at the free surface level).
- If the cells are not aligned, this may introduce spurious oscillations which might or might not be significant.
- In this case, the hexahedral cells are aligned with the free surface.
 - The quality of the solution at the free surface is much better than the solution with the polyhedral mesh.
 - Also, the error associated with this mesh is much lower than the error associated with the polyhedral mesh.

Introduction to multiphase flows

Multiphase flows simulations

Wave impact in a column

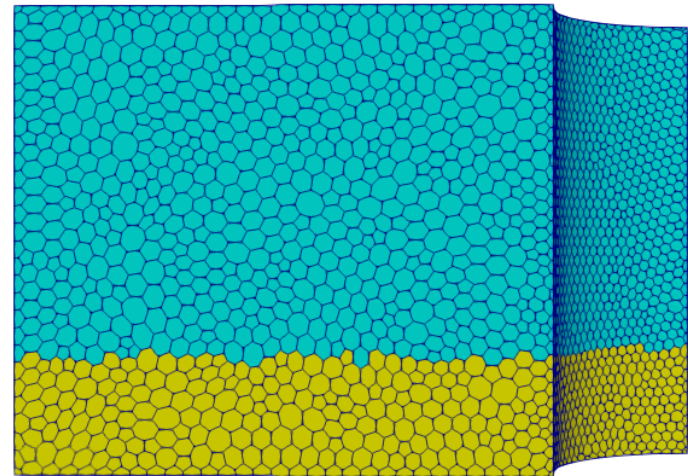
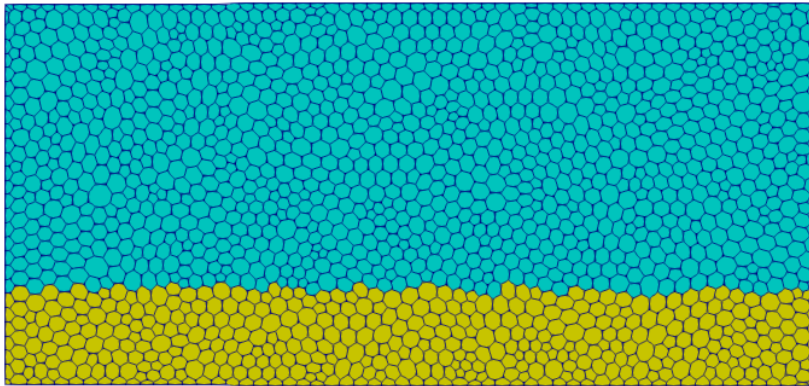

- When conducting free surface simulations, it is extremely important to generate a mesh that is aligned with the free surface level (at least at the free surface level).
- If the cells are not aligned, this may introduce spurious oscillations which might or might not be significant.
- In this case, the hexahedral cells are aligned with the free surface.
 - The quality of the solution at the free surface is much better than the solution with the polyhedral mesh.
 - Also, the error associated with this mesh is much lower than the error associated with the polyhedral mesh.

Introduction to multiphase flows

Multiphase flows simulations

Wave impact in a column

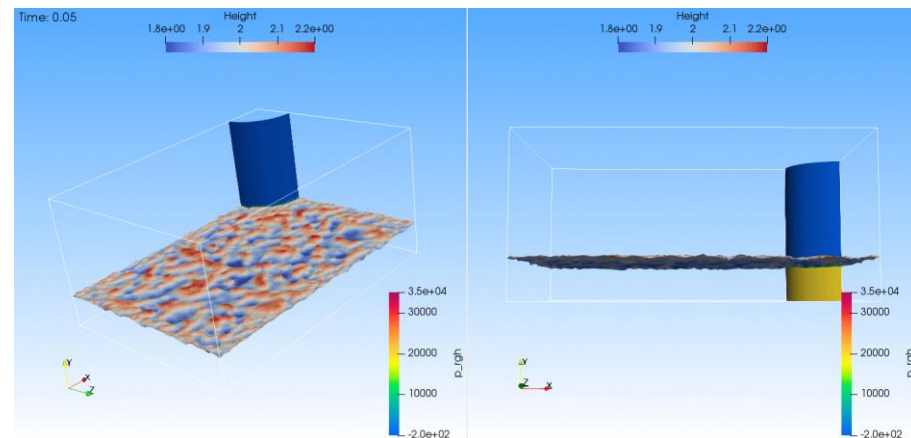
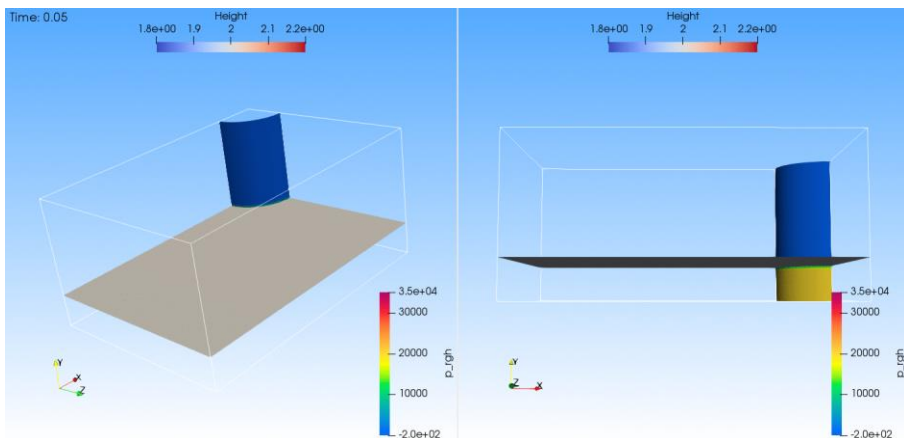
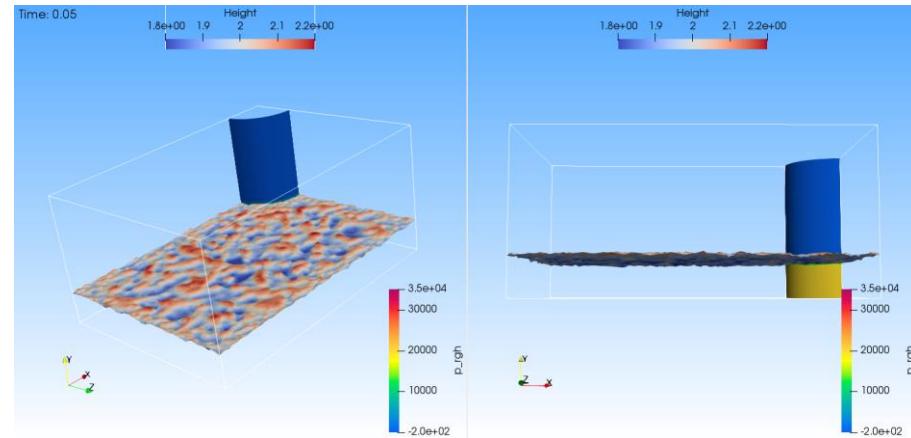
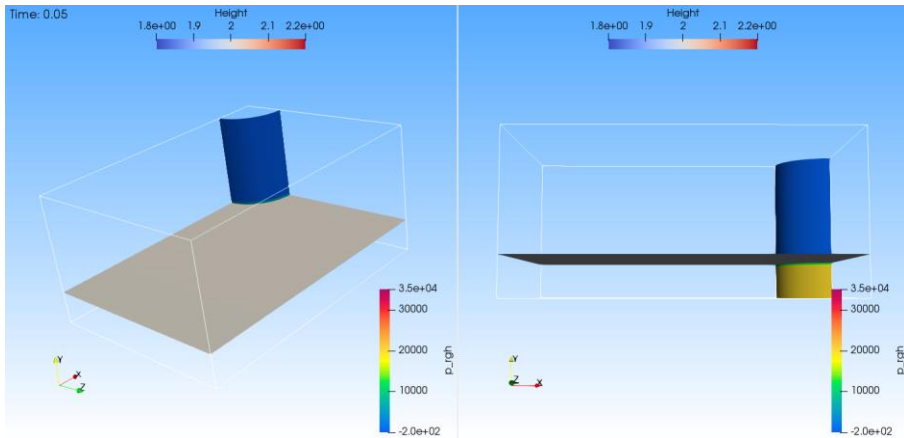

Hexahedral mesh

<http://www.wolfdynamics.com/training/mphase/gt1/hexa/ani1.gif>

Polyhedral mesh

<http://www.wolfdynamics.com/training/mphase/gt1/poly/ani1.gif>

Introduction to multiphase flows

Multiphase flows simulations

Wave impact in a column

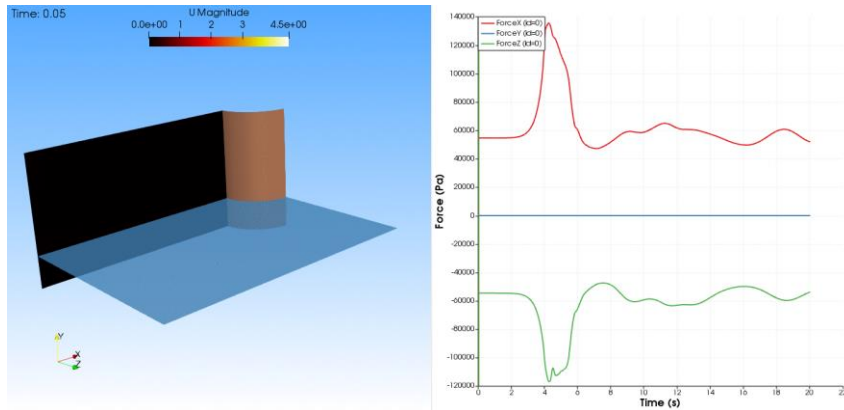

<http://www.wolfdynamics.com/training/mphase/gt1/hexa/ani3.gif>

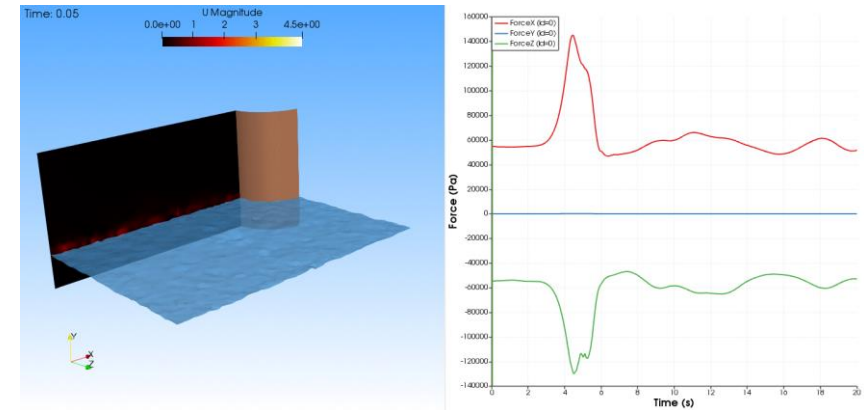

<http://www.wolfdynamics.com/training/mphase/gt1/tetra/ani3.gif>

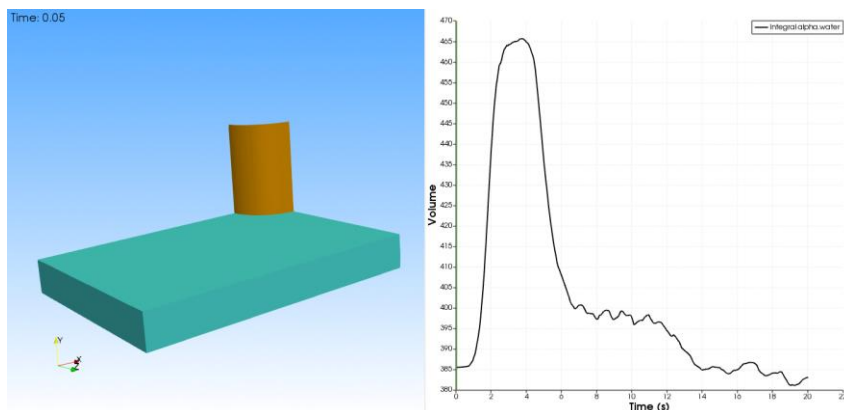

<http://www.wolfdynamics.com/training/mphase/gt1/hexa/ani5.gif>

Hexahedral mesh

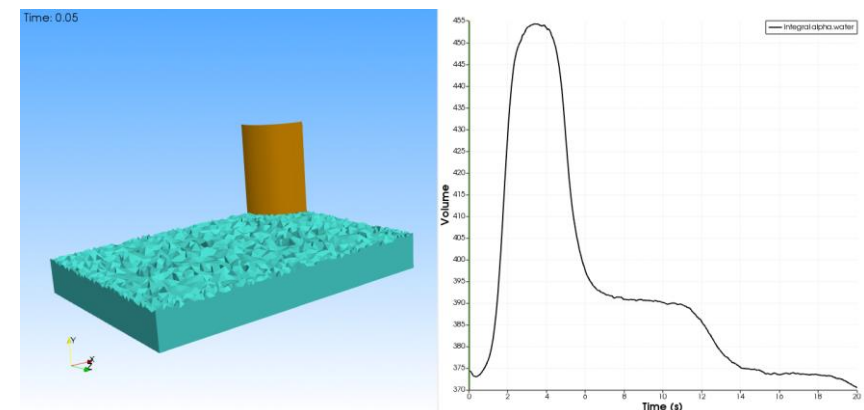

<http://www.wolfdynamics.com/training/mphase/gt1/tetra/ani5.gif>

Tetrahedral mesh

Introduction to multiphase flows

Multiphase flows simulations

Wigley Hull – Towing tank



Time: 0.25

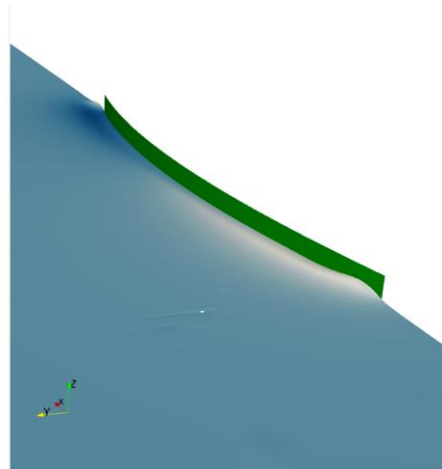
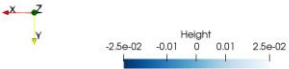
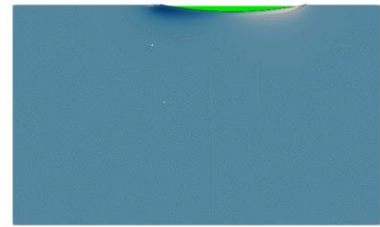

Time: 0.25

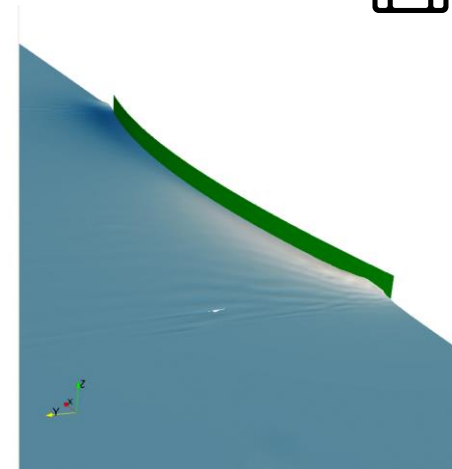
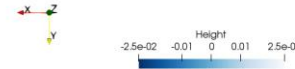
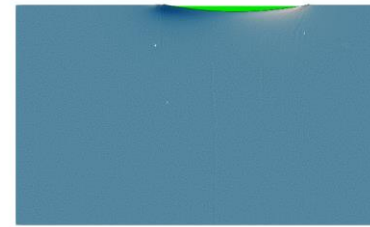

Unsteady simulation

Free surface colored by height – VOF CFL = 1

<http://www.wolfdynamics.com/training/mphase/gt2/uns1.gif>

Unsteady simulation

Free surface colored by height – VOF CFL = 10

<http://www.wolfdynamics.com/training/mphase/gt2/uns2.gif>

Introduction to multiphase flows

Multiphase flows simulations

Wigley Hull – Towing tank

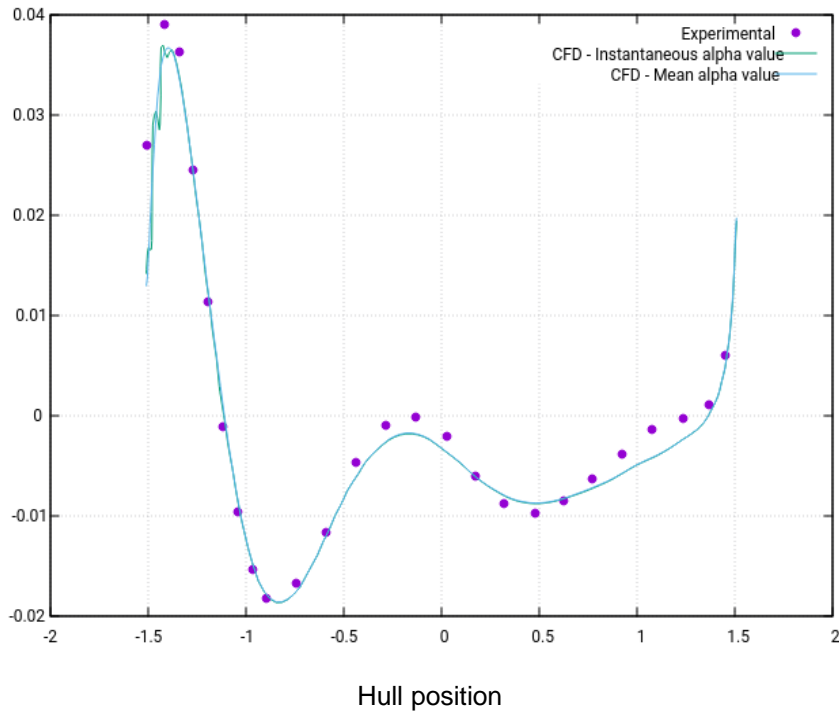

Comparison of water level on hull surface

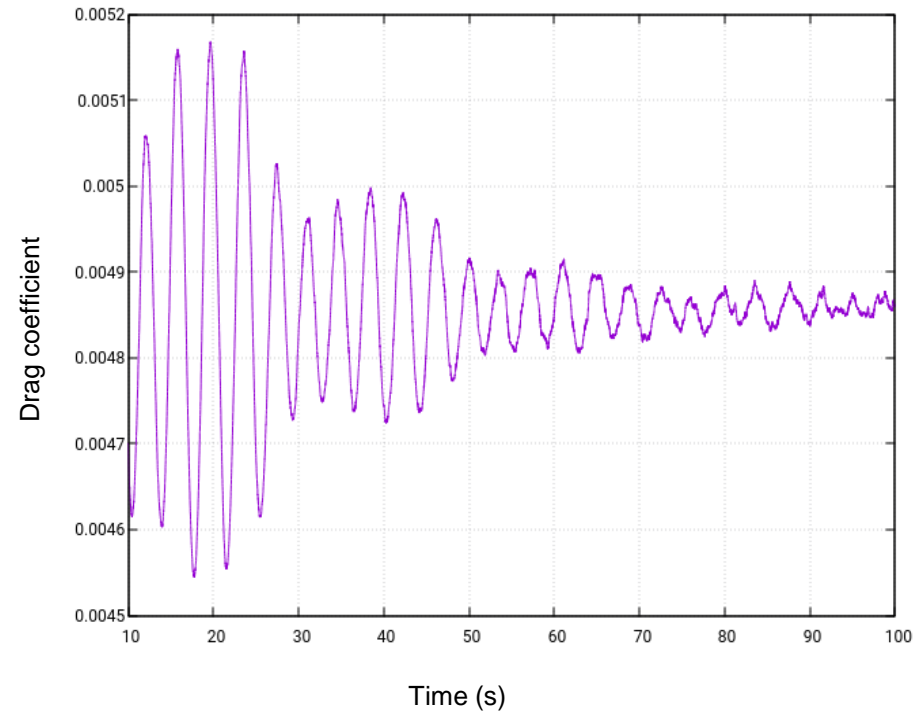

Drag coefficient monitor

Introduction to multiphase flows

Multiphase flows simulations

Wigley Hull – Towing tank

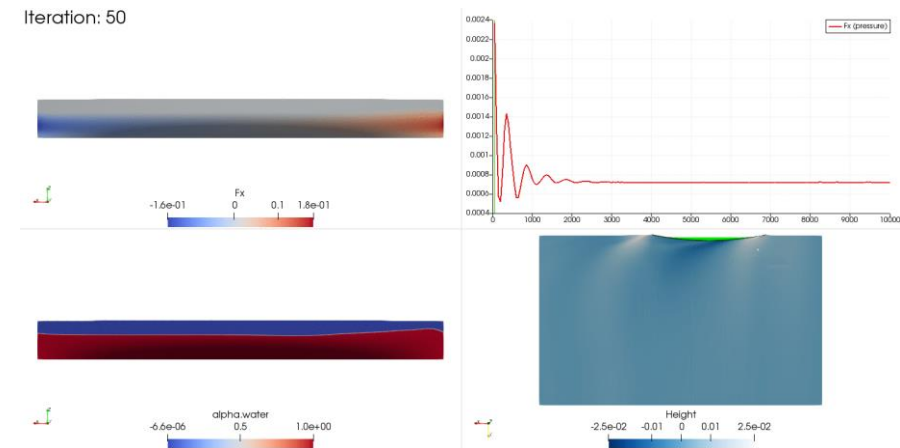
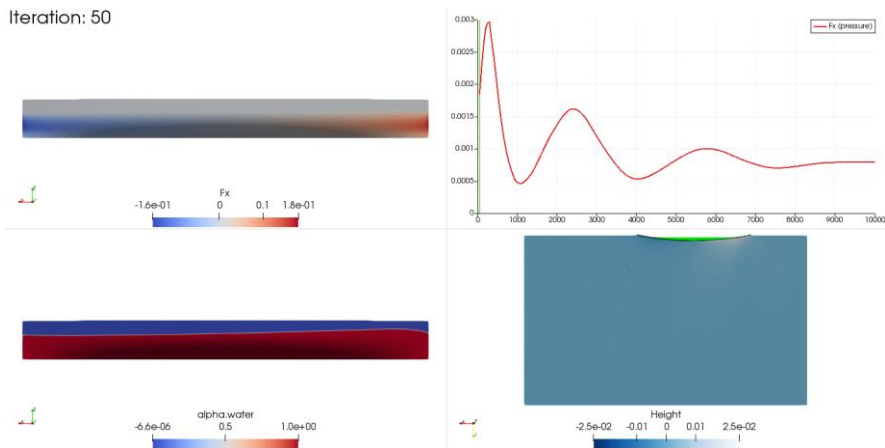

Local-time stepping (LTS) simulation
Free surface colored by height – VOF CFL = 0.9
<http://www.wolfdynamics.com/training/mphase/gt2/LTS2.gif>

Local-time stepping (LTS) simulation
Free surface colored by height – VOF CFL = 4
<http://www.wolfdynamics.com/training/mphase/gt2/LTS1.gif>

Introduction to multiphase flows

Multiphase flows simulations

Dispersed bubbles in a continuous phase

Similar to turbulence modeling, modeling the individual behavior of each bubble is too expensive. Thus, the need of dispersed models in multiphase flows.

Time: 1.000000

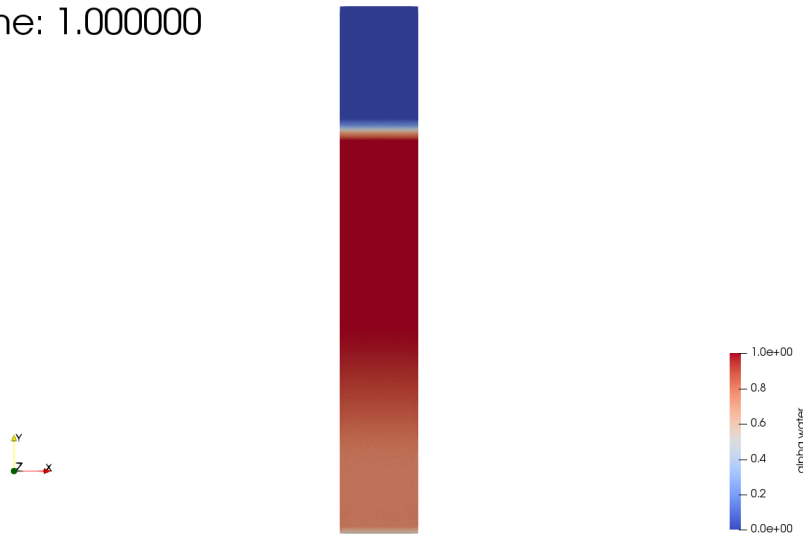

<http://www.wolfdynamics.com/training/mphase/image17.gif>

Time: 0.5

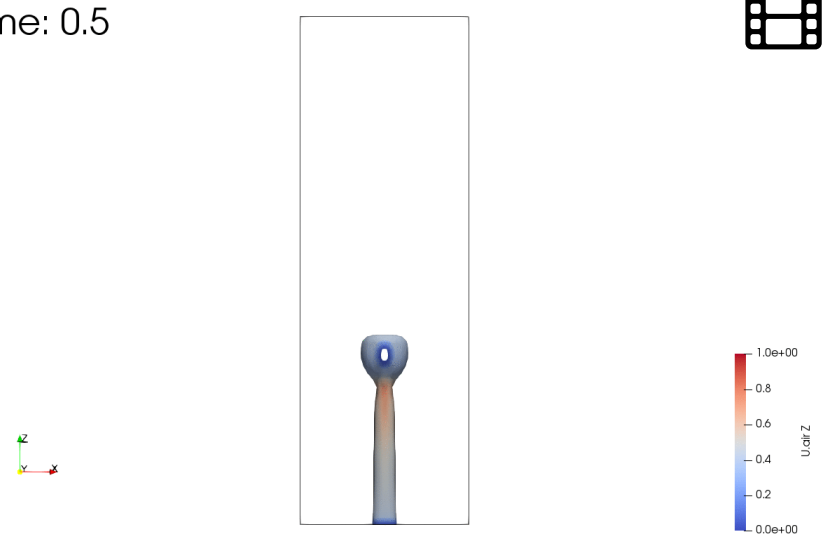

<http://www.wolfdynamics.com/training/mphase/image18.gif>

Introduction to multiphase flows

Multiphase flows simulations

Particle injection in a mixing tank



Time: 0.050

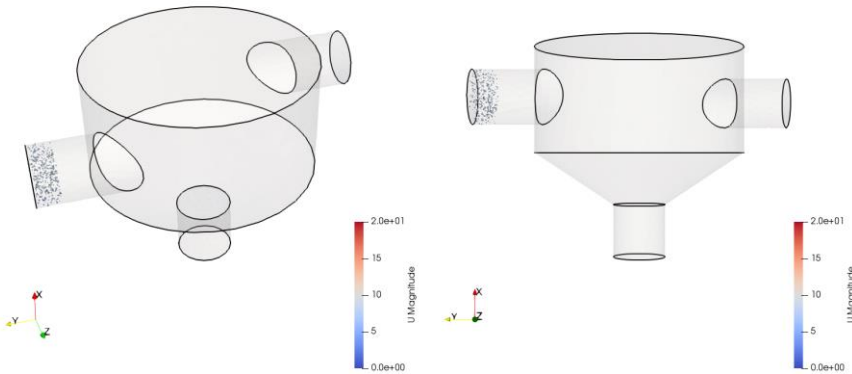

Time: 0.050

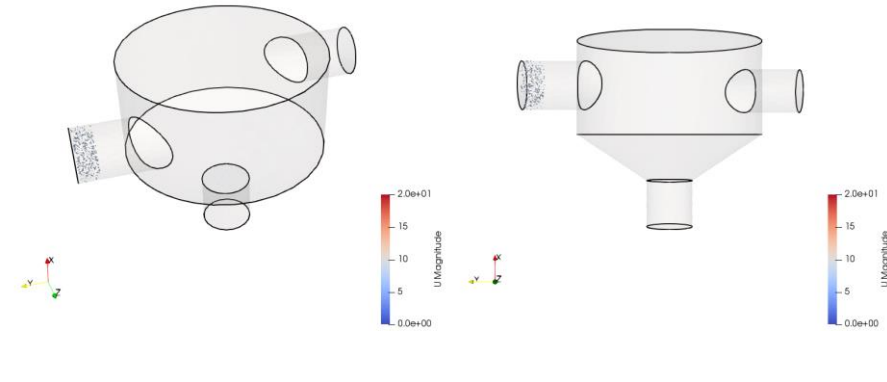

Laminar solution – No packing model

<http://www.wolfdynamics.com/training/mphase/image54.gif>

Turbulent solution – No packing model

<http://www.wolfdynamics.com/training/mphase/image55.gif>

Introduction to multiphase flows

Multiphase flows simulations

Particle injection in a mixing tank



Time: 0.050

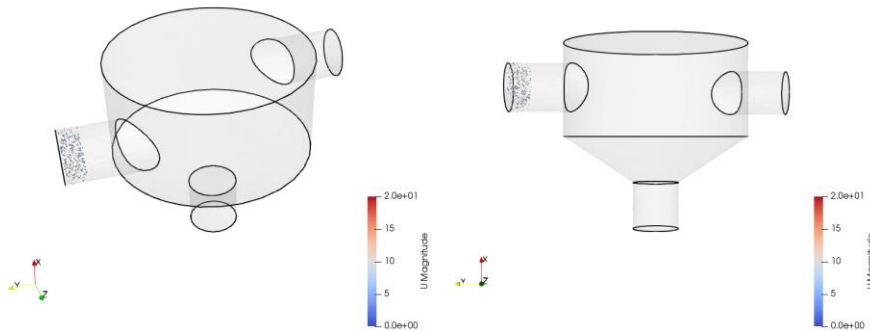

Time: 0.050

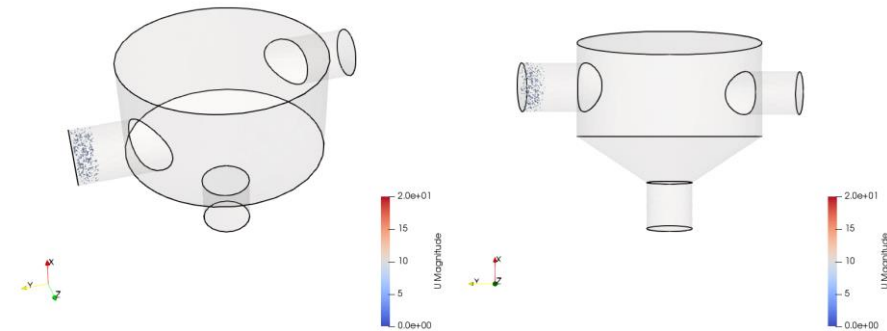

Turbulent solution – No packing model

<http://www.wolfdynamics.com/training/mphase/image55.gif>

Turbulent solution – Implicit packing model

<http://www.wolfdynamics.com/training/mphase/image56.gif>

Introduction to multiphase flows

Multiphase flows simulations

Particle injection in a mixing tank



Time: 0.050

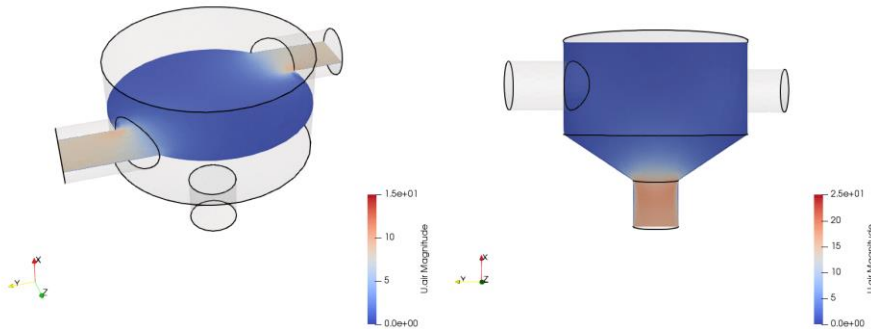

Time: 0.050

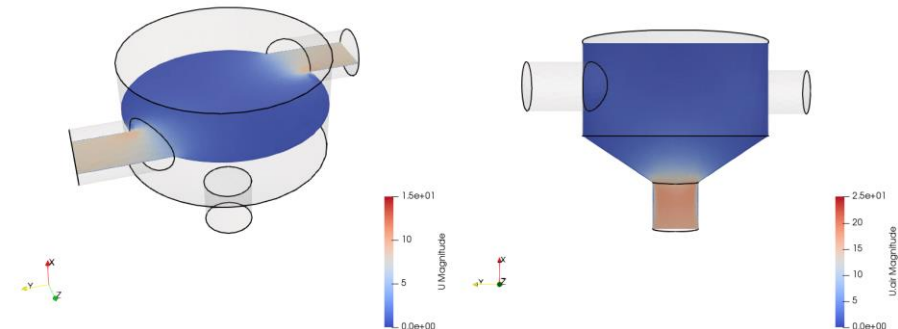

Turbulent solution – No packing model

<http://www.wolfdynamics.com/training/mphase/image57.gif>

Turbulent solution – Implicit packing model

<http://www.wolfdynamics.com/training/mphase/image58.gif>

Modeling approaches for multiphase flows

Modeling approaches for multiphase flows

Overview/remarks on modeling approaches

- Simulating multiphase flows is not an easy task.
- The complex nature of multiphase flows is due to:
 - The transient nature of the flows.
 - The existence of dynamically changing interfaces.
 - Significant discontinuities (fluid properties and fluid separation).
 - Complicated flow field near the interface.
 - Interaction of small-scale structures (bubbles and particles).
 - Particle-particle interactions.
 - Mass transfer and phase change.
 - Turbulence.
 - Phase dispersion, mixing and transport of quantities.
 - Heterogenous and homogenous reactions.

Modeling approaches for multiphase flows

Overview/remarks on modeling approaches

- Multiphase flows are inherently multi-scale in nature.
- Like in turbulence, we must account for the cascade effect of the various flow physics at different scales:
 - Large flow structures within the fluid flow (system-scale).
 - Local structural changes due to coalescence and breakage processes (meso-scales).
 - Motion and interaction of discrete constituents or small particles (micro-scale).
- And on top of this, we have turbulence models.
- You can also have cavitation.
- And to make it even more difficult, you can have phase change, mass transfer, and chemical reactions.

Modeling approaches for multiphase flows

Overview/remarks on modeling approaches

Free surface (system scale)

Multiphase flows are transient and multiscale

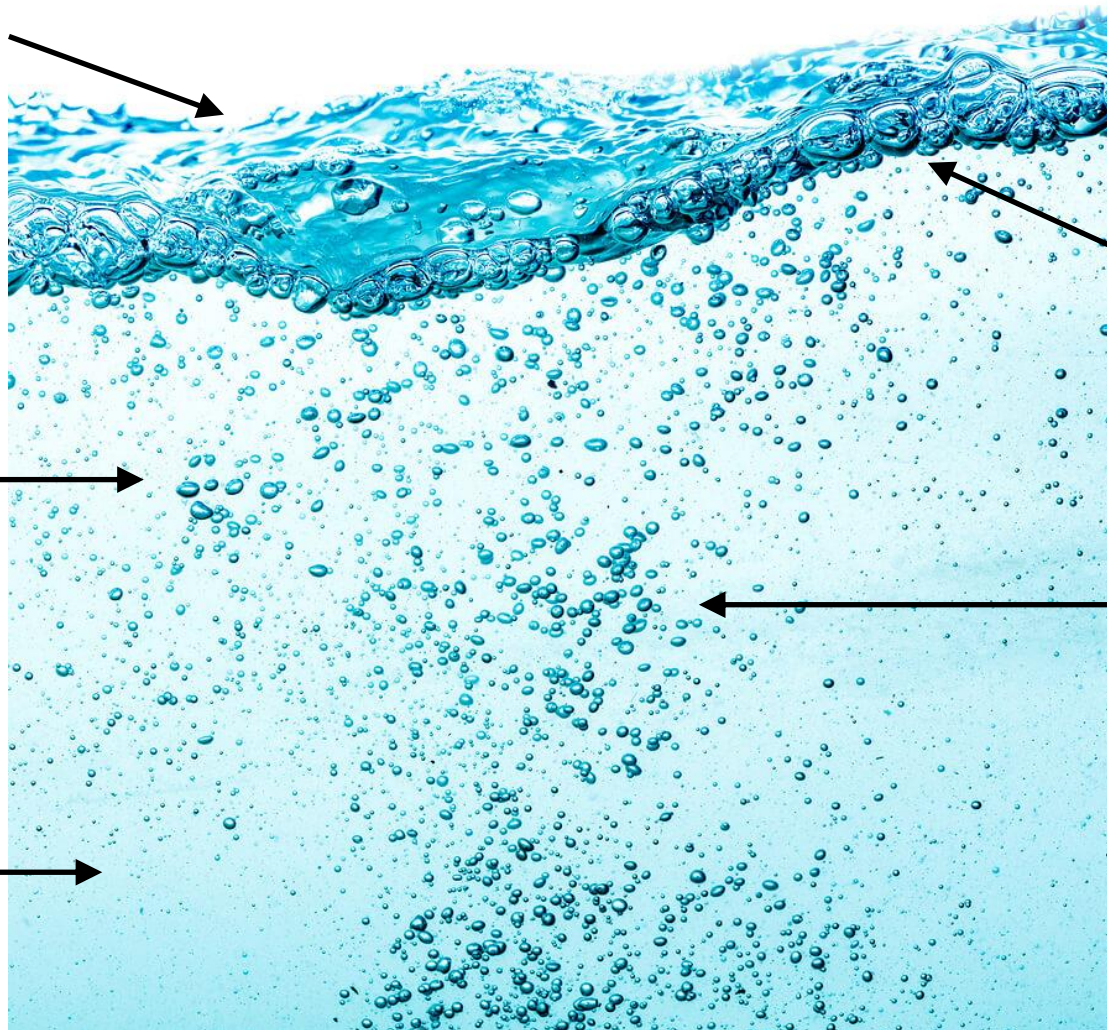

Large bubbles (system scale)

Medium bubbles (system-scales)

Bubble break-up and coalescence (meso-scales)

Small bubbles interaction and motion of small particles (micro-scales)

Modeling approaches for multiphase flows

Overview/remarks on modeling approaches

- With today's computational resources, it is possible to solve directly multiphase flows and compute every detail of the flow. These are fully resolved simulations (kind of DNS).
- In the fully resolved approach we have a complete insight of the motion of the fluid system and every particle transported, bubbles and droplets, and the position of every interface.
- Such detailed and comprehensive treatment is restricted to low Reynolds number flows and for a limited number of particles, bubbles and droplets, due to limits in computational resources and simulation time.
- Macroscopic formulation of multiphase flows, based on models, enables simulation of large-scale, highly turbulent, and complex multiphase systems at a reduced computational cost.
- The predictions highly depends on realistic closure models for the interfacial exchange of mass, momentum and energy, as well as turbulent effects.
- Models, models, models.

Modeling approaches for multiphase flows

How to treat the wide range of behaviors in multiphase flows

- **Fully resolved:** solves complete physics. All spatial and temporal scales are resolved.
- **Eulerian-Lagrangian:** solves idealized isolated particles that are transported with the flow. One- or two-way coupling is possible. Can account for turbulence, momentum transfer, and mass transfer.
- **Eulerian-eulerian:** solves two or more co-existing fluids. The system can be dispersed or separated, and can account for turbulence, momentum transfer, and mass transfer.

Increase

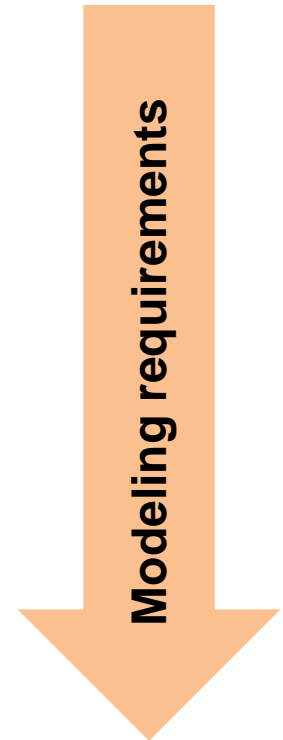
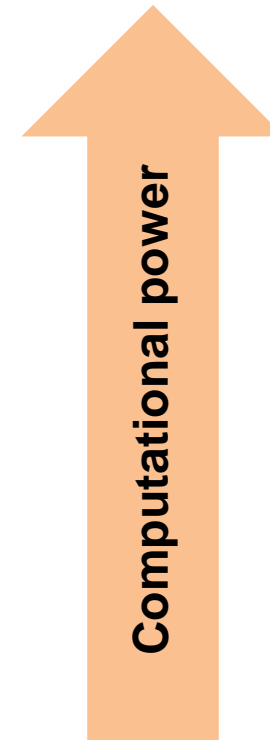

Increase

Modeling approaches for multiphase flows

How to treat the wide range of behaviors in multiphase flows

- As in turbulence modeling, we can take an approach that resolves all scales, but it is too expensive.
- Therefore, the need of using models.
- And depending on the multiphase system, there are models very specific for the multiphase physics involved.
- Multiphase flows are heavily modeled.

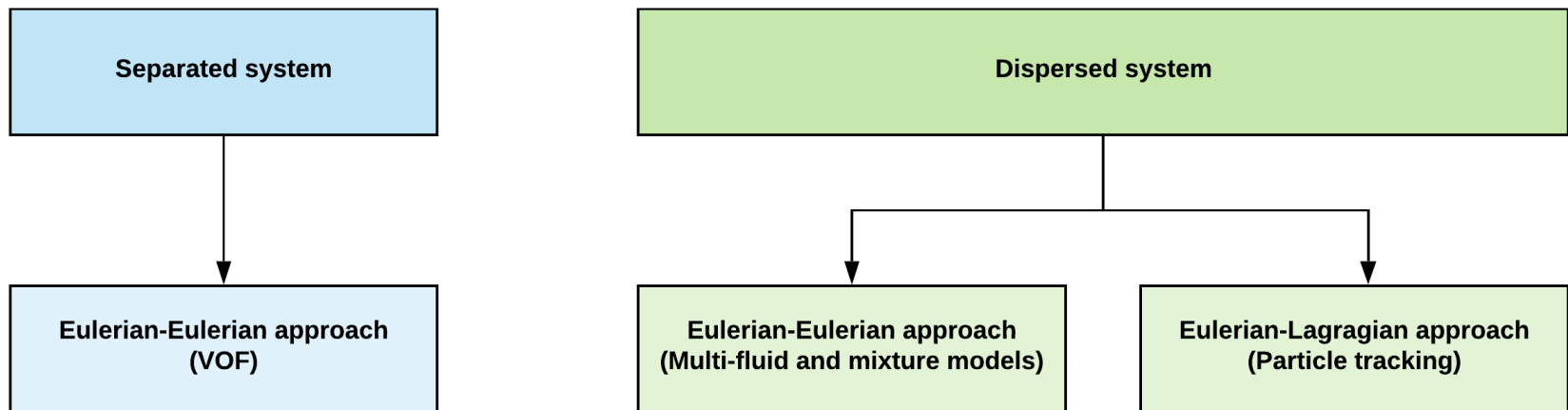

Modeling approaches for multiphase flows

How to treat the wide range of behaviors in multiphase flows

- Turbulence modeling is on top of every type of physics to be simulated, including multiphase flows.
- Turbulence has a strong influence of the dynamics of multiphase flows, at large and small scales.

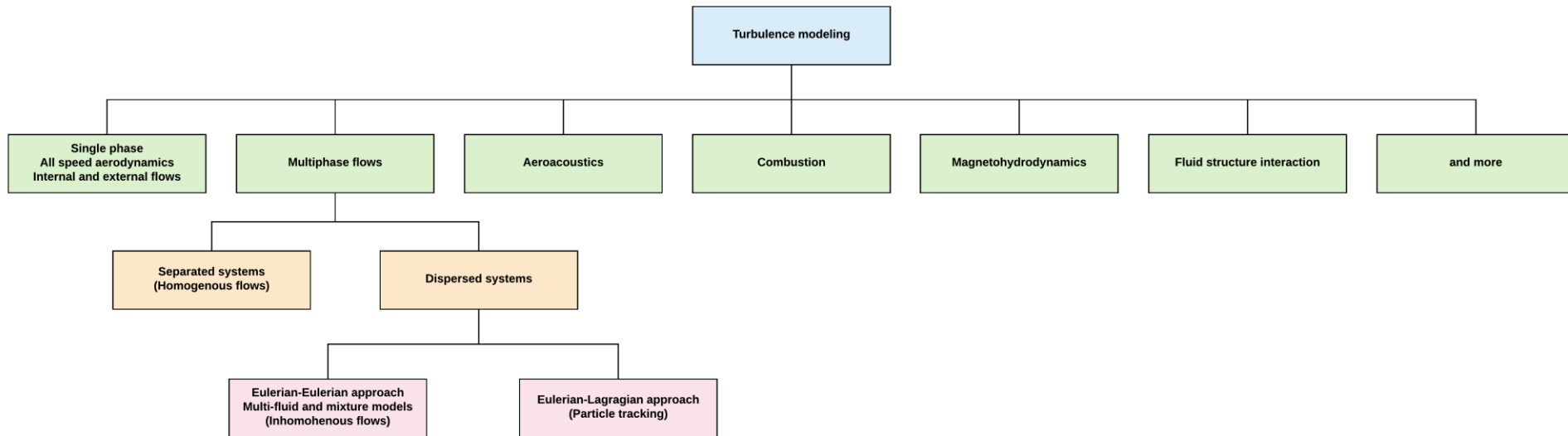

Modeling approaches for multiphase flows

How to treat the wide range of behaviors in multiphase flows

Free surface

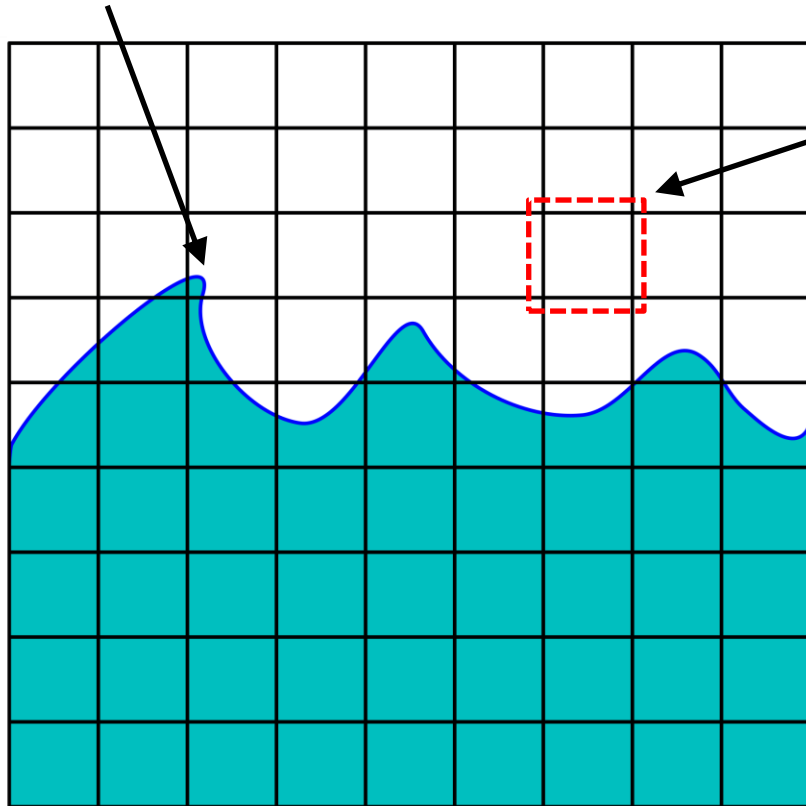

Bubbles larger than cell size

Cell size

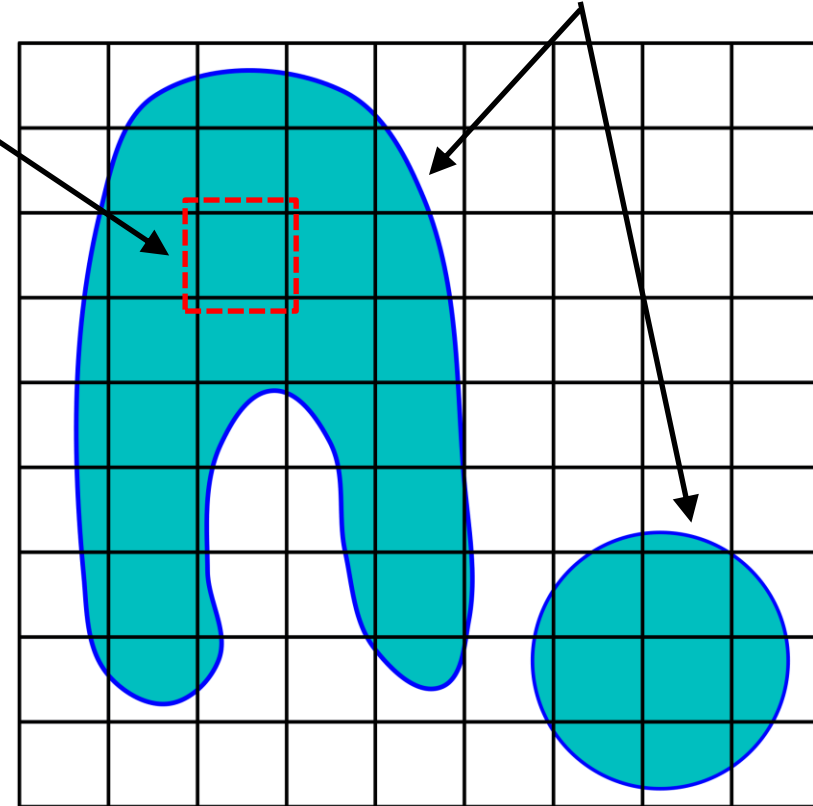

Free surface flows and surface tracking at scales larger than grid size Applicability of VOF method to separated systems (non-interpenetrating continua)

Modeling approaches for multiphase flows

How to treat the wide range of behaviors in multiphase flows

Not ok. Only one cell to resolve the bubble.

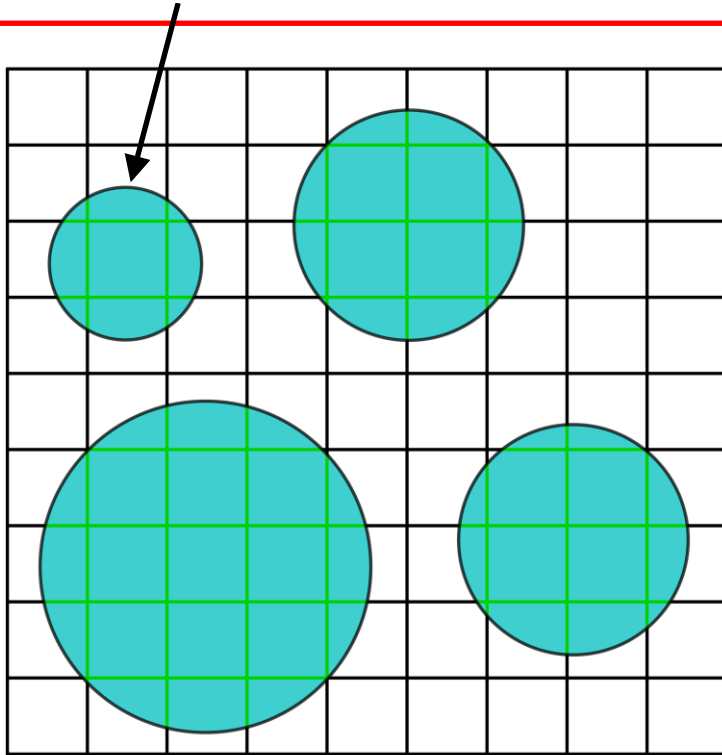

- Bubbles, droplets and/or particles bigger than grid scales (GS), can be resolved using VOF.
- To roughly resolve a bubble, you will need to use at least two cells in every direction.

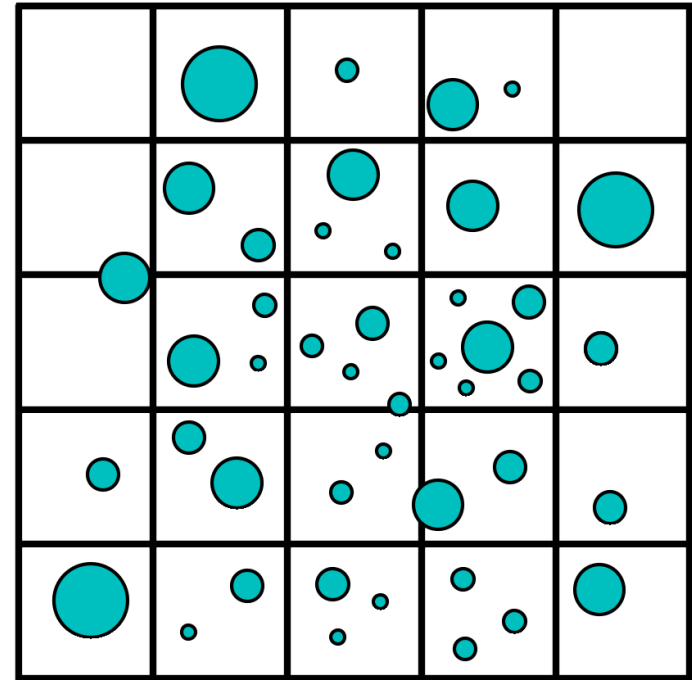

- Bubbles, droplets and/or particles smaller than grid scales (sub-grid scales or SGS), can not be resolve using the VOF method.
- In this case, we need to use models to compute the disperse phase.

Modeling approaches for multiphase flows

How to treat the wide range of behaviors in multiphase flows

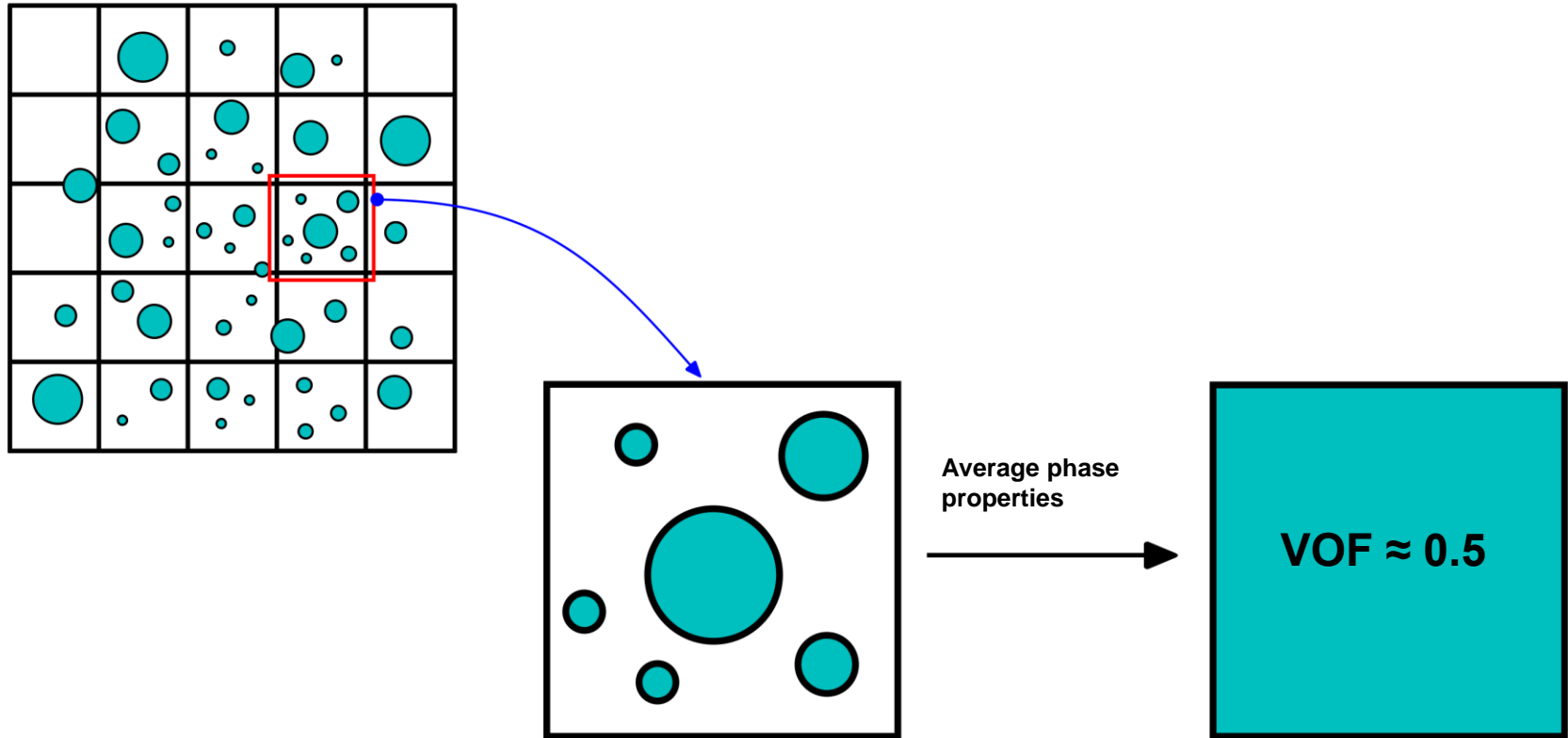

Dispersed phase in a continuous phase
VOF is not able to handle bubbles smaller than grid scales

Modeling approaches for multiphase flows

How to treat the wide range of behaviors in multiphase flows

Coalescence mechanism

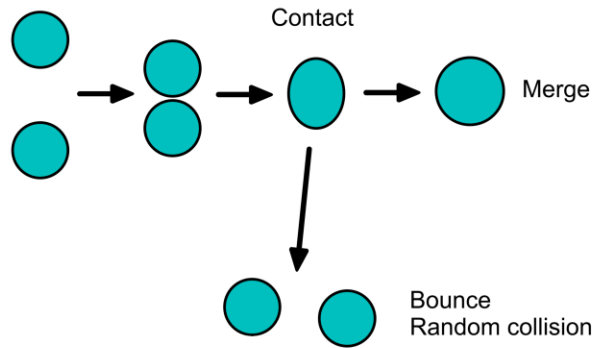

Wake entrainment



Break-up mechanism

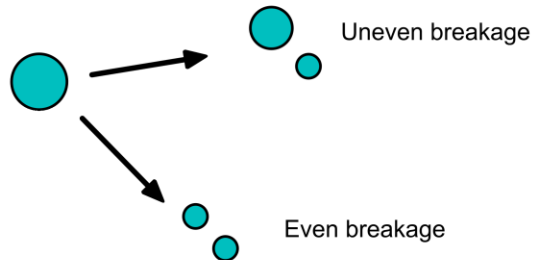

Bubble coalescence, bubble break-up and wake entrainment in dispersed systems

Modeling approaches for multiphase flows

How to treat the wide range of behaviors in multiphase flows



Time: 0.00

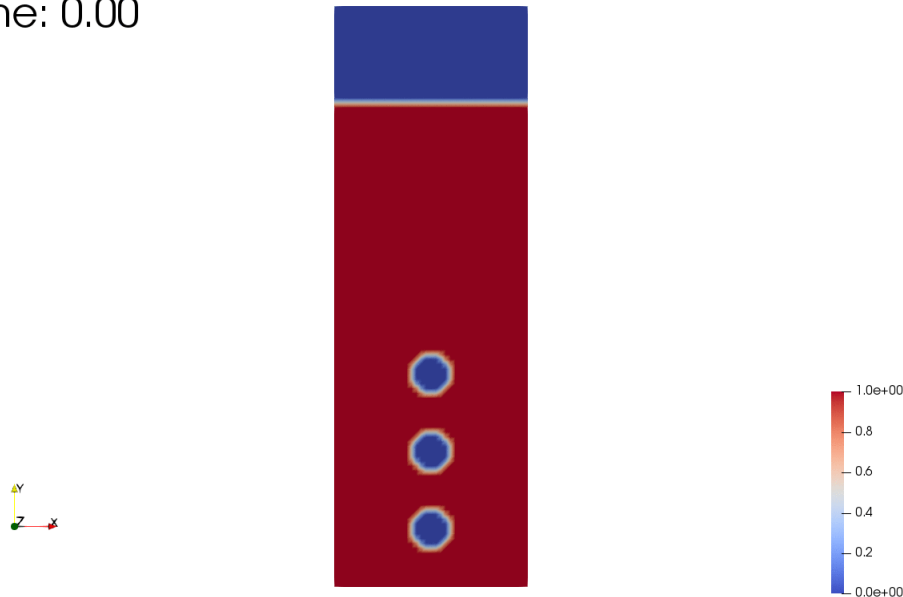

<http://www.wolfdynamics.com/training/mphase/image2.gif>

Time: 0.00

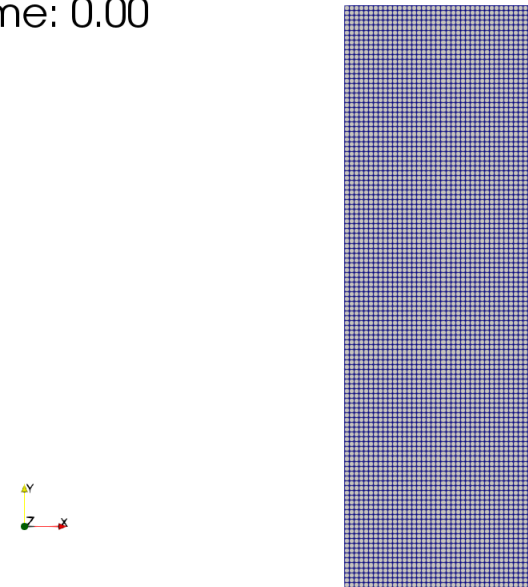

<http://www.wolfdynamics.com/training/mphase/image3.gif>

Bubble coalescence, bubble break-up and wake entrainment

In this simulation the bubbles are capture by using AMR. However, the smallest bubble that can be resolved is at the smallest grid size.

Modeling approaches for multiphase flows

How to treat the wide range of behaviors in multiphase flows

Time: 0.01

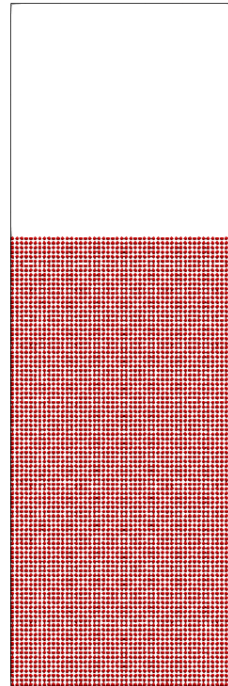

<http://www.wolfdynamics.com/training/mphase/image46.gif>

Particulate flows – Gas-solid interaction and particle-particle interaction

In this simulation the particles are simulated using an Eulerian-Lagrangian approach. The model takes into account particle-particle interaction and turbulence modeling.

Modeling approaches for multiphase flows

How to treat the wide range of behaviors in multiphase flows

- Eulerian mesh.
- This is the mesh where the NSE are solved.

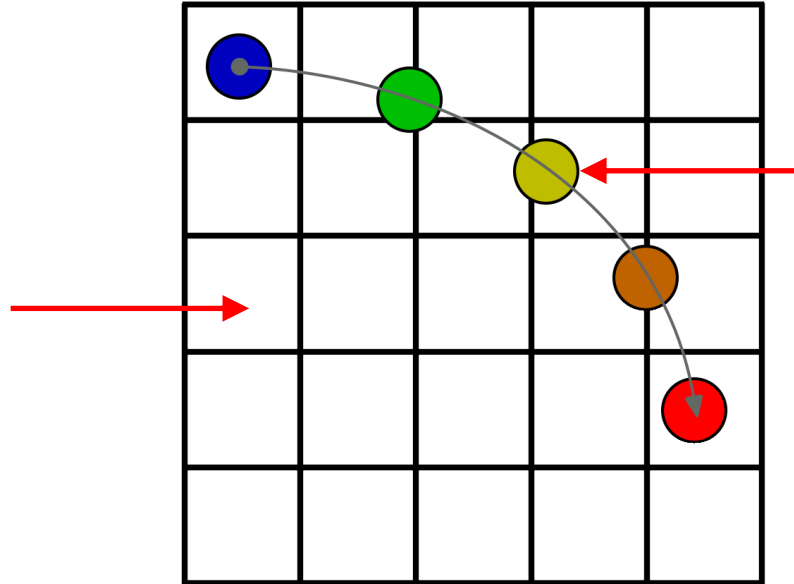

- Lagrangian mesh.
- This is not an actual mesh (like in the Eulerian case), it is a terminology for the particles.
- The equations of motion are solved for each single particle.

- **Eulerian-Lagrangian approach:**
 - The particles can be smaller or larger than the grid size.
 - Can have couple or uncoupled hydrodynamics.
 - For the hydrodynamic coupling, different approaches are available.
 - The particles move according to the flow momentum, and their position is tracked at all times.
 - The particles can interact with the boundaries: escape, bounce, stick, wall film, react, and so on.
 - Can account for particles interaction and mass transfer.
 - Different injection models and particle interaction models can be selected.

Modeling approaches for multiphase flows

How to treat the wide range of behaviors in multiphase flows

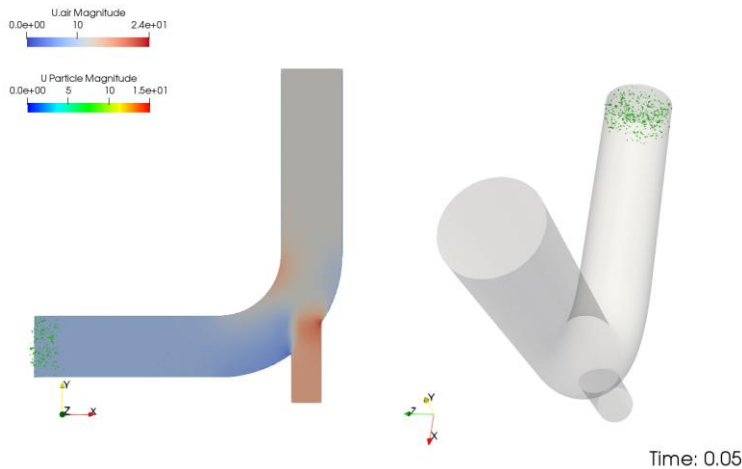

Hydrodynamic coupling with gravity

<http://www.wolfdynamics.com/training/mphase/image30.gif>

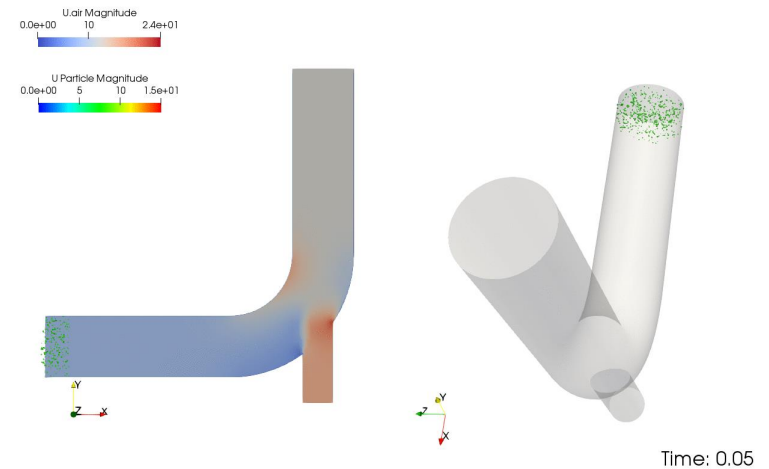

Hydrodynamic coupling with no gravity

<http://www.wolfdynamics.com/training/mphase/image30a.gif>

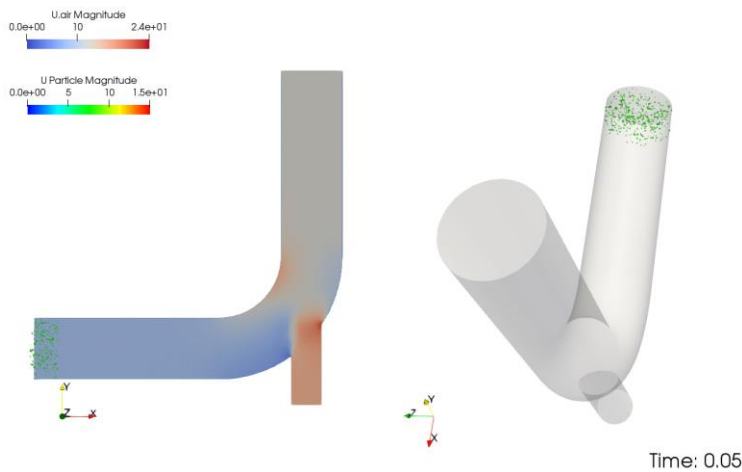

No hydrodynamic coupling with gravity

<http://www.wolfdynamics.com/training/mphase/image31.gif>

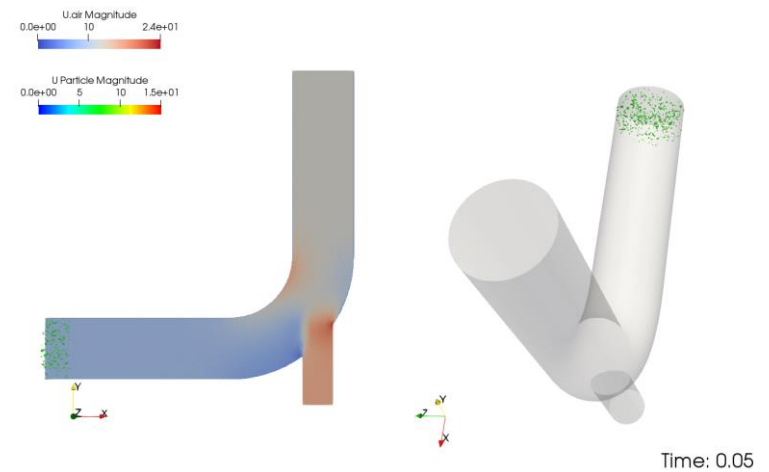

No hydrodynamic coupling with no gravity

<http://www.wolfdynamics.com/training/mphase/image31a.gif>

Modeling approaches for multiphase flows

Characteristics of particulate flows

- Particle-particle interactions.

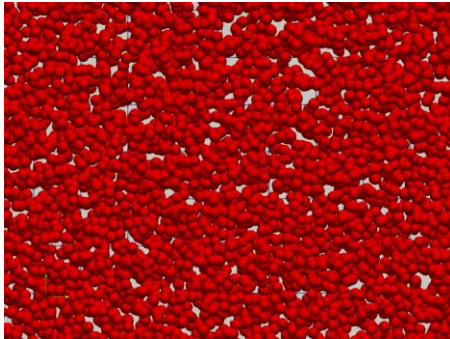

Dense flow

- Frictional dominated.
- Slow flows.
- Strain rate independent.
- Four-way coupling.
- Solid mechanics (Schaeffer, 1987).

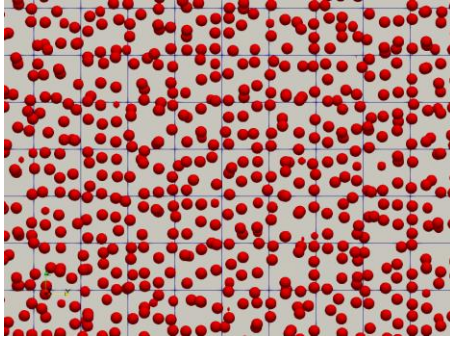

Intermediate flow – Transition regime

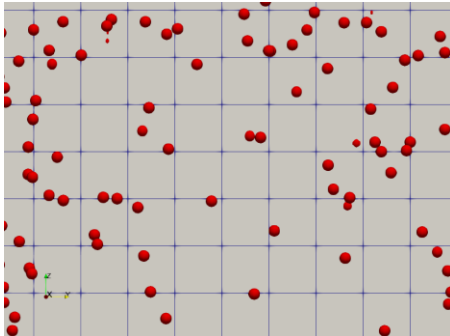

Dilute flow

- Collision dominated
- Rapid flow
- Strain rate dependent
- One-way and two-way coupling.
- Kinetic Theory (Lun, 1984)

More



Less

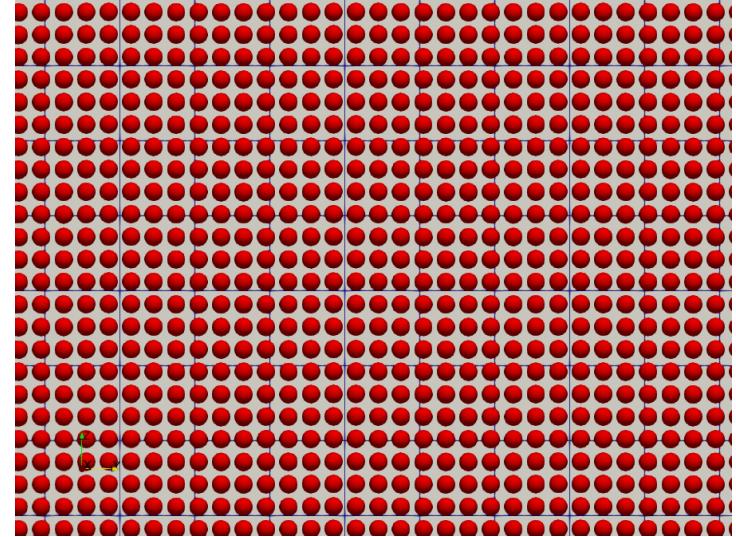

Particles concentration

<http://www.wolfdynamics.com/training/mphase/image47.gif>

Modeling approaches for multiphase flows

Challenges of modeling multiphase flows

- Interface separating the two phases is extremely thin and discontinuous.
- Density change across the interface is large.
- Interface exerts surface tension force on the liquid phase.
- Topology changes in vast length and time scales.
- Separated flow system, dispersed flow system and particles can be present in the same problem.
- Reactions and phase change.
- Example of a challenging problem: atomization of a liquid jet and combustion.

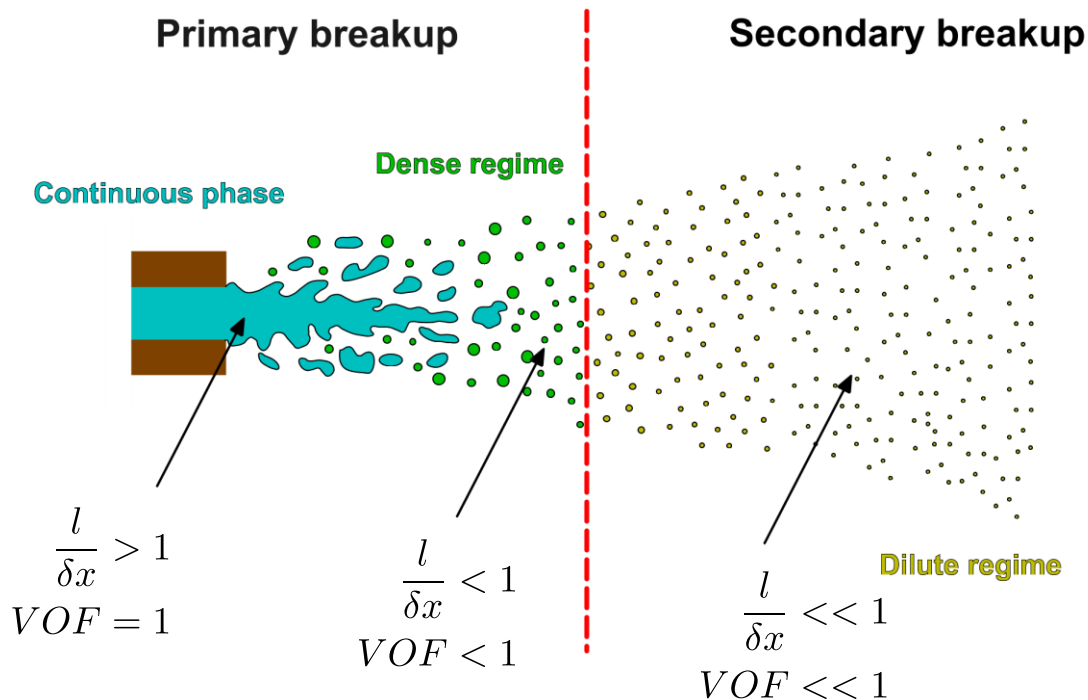

Dense regime: particles motion is controlled primarily by particle-particle collisions.

Dilute regime: particle motion is controlled by the drag and lift forces on the particle (particles follow the fluid flow).

$$\text{volume fraction of a phase} = \frac{\text{volume of the phase in a cell/domain}}{\text{volume of the cell/domain}}$$

δx = grid resolution

VOF = liquid volume fraction

l = liquid characteristic length scale

Governing equations and interfacial momentum transfer models

Volume-of-Fluid (VOF) governing equations for separated systems

Time: 0.000000

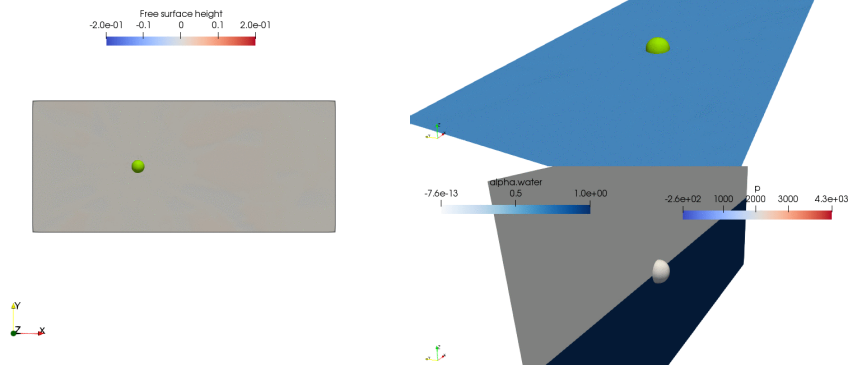

Time: 0.050000

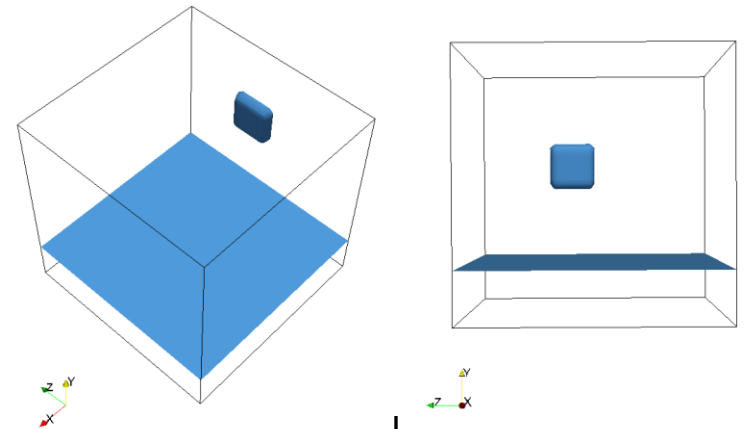

Governing equations and interfacial momentum transfer models

Volume-of-Fluid (VOF) governing equations for separated systems

- The incompressible, isothermal governing equations can be written as follows,

$$\nabla \cdot \mathbf{U} = 0$$

$$\frac{\partial \rho \mathbf{U}}{\partial t} + \nabla \cdot (\rho \mathbf{U} \mathbf{U}) = -\nabla p + \nabla \cdot \tau + \rho g + f_{\sigma} + \rho S$$

Surface tension

Source terms:

- Porous media
- Coriolis forces
- Centrifugal forces
- Mass transfer
- and so on ...

Governing equations and interfacial momentum transfer models

Volume-of-Fluid (VOF) governing equations for separated systems

- Phase transport equation and interface tracking with surface compression,

$$\frac{\partial \gamma}{\partial t} + \nabla \cdot \mathbf{U} \gamma + \nabla \cdot (\mathbf{U}_r \gamma (1 - \gamma)) = 0$$

$$0 < \gamma < 1$$

Volume fraction

Interface compression velocity

- You can see the volume fraction γ as a pointer that indicates what phase (with the corresponding physical properties), is inside each cell of the computational domain.

Governing equations and interfacial momentum transfer models

Volume-of-Fluid (VOF) governing equations for separated systems

- For example, in the case of two phases where phase 1 is represented by $\gamma = 1$ and phase 2 is represented by $\gamma = 0$; a volume fraction value of 1 indicates that the cell is fill with phase 1; a volume fraction of 0.8 indicates that the cell contains 80% of a phase 1; and a volume fraction of 0, indicates that the cell is fill with phase 2.
- The values between 0 and 1 can be seen as the interface between the phases.
- The fluid properties can be written on either side of the interface as follows,

$$\rho = \gamma_1 \rho_1 + (1 - \gamma_1) \rho_2$$

$$\mu = \gamma_1 \mu_1 + (1 - \gamma_1) \mu_2$$

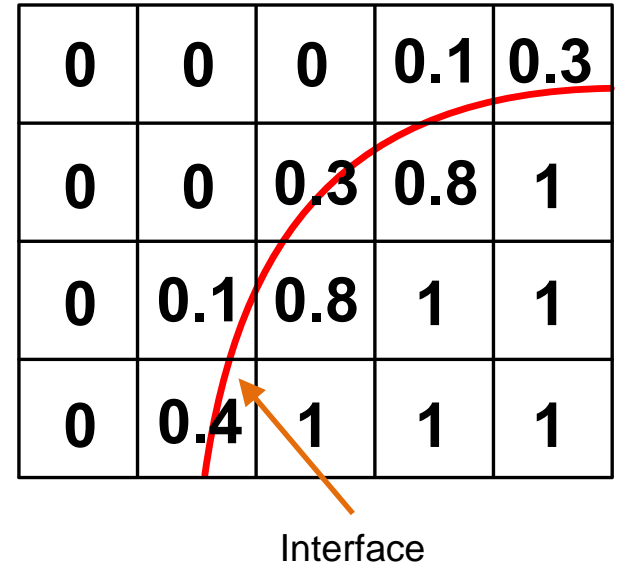

Volume-of-Fluid (VOF) governing equations for separated systems

- Phase transport equation and interface tracking with surface compression,

$$\frac{\partial \gamma}{\partial t} + \nabla \cdot \mathbf{U} \gamma + \nabla \cdot (\mathbf{U}_r \gamma (1 - \gamma)) = 0$$

$$\mathbf{U}_r = \min(c_\gamma |\mathbf{U}|, \max(|\mathbf{U}|)) \cdot \mathbf{n}$$



- Coefficient to control the magnitude of the compression (cAlpha).
- Usually $0 < c\text{Alpha} < 2$.
- Recommended value 1.

Governing equations and interfacial momentum transfer models

Volume-of-Fluid (VOF) governing equations for separated systems

- Continuum surface force (CSF) model for the calculation of the surface tension,

$$\frac{\partial \rho \mathbf{U}}{\partial t} + \nabla \cdot (\rho \mathbf{U} \mathbf{U}) = -\nabla p + \nabla \cdot \tau + \rho g + f_{\sigma} + \rho S$$

Surface tension coefficient

$$f_{\sigma} = \sigma k \nabla \gamma$$

$$k = \nabla \cdot \left(\frac{\nabla \gamma}{|\nabla \gamma|} \right)$$

- k represents the local curvature, based on local gradients.
- The CSF model neglects the effects of a variable surface tension coefficient.

Governing equations and interfacial momentum transfer models

Volume-of-Fluid (VOF) governing equations for separated systems

- In the VOF method, the curvature calculations are based on the volume fraction field.

$$k = \nabla \cdot \left(\frac{\nabla \gamma}{|\nabla \gamma|} \right)$$

- Calculation of curvature based on volume fractions can be inaccurate and cause convergence issues in problems dominated by surface tension.
- It is recommended not to use aggressive slope limiters when computing the local curvature.
- The curvature resolution should be as smooth as possible.

Time: 0.000000



Smooth slope limiter used for curvature computations
<http://www.wolfdynamics.com/training/mphase/image48.gif>

Time: 0.000000



Aggressive slope limiter used for curvature computations
<http://www.wolfdynamics.com/training/mphase/image49.gif>

Governing equations and interfacial momentum transfer models

Volume-of-Fluid (VOF) governing equations for separated systems

- To determine if the effects of surface tension are important, first evaluate the Reynolds number and then,
 - For $Re \ll 1$ compute the Capillary number:

$$Ca = \frac{\mu \mathbf{U}}{\sigma}$$

- For $Re \gg 1$ compute the Weber number:

$$We = \frac{\rho L \mathbf{U}^2}{\sigma}$$

- Surface tension is important when $Ca \ll 1$ or $We \ll 1$.
- At large scales, the effects of surface tension can be neglected.

Governing equations and interfacial momentum transfer models

Volume-of-Fluid (VOF) governing equations for separated systems

- Wall adhesion and contact angle:

- It is possible to model contact angles and adhesives forces acting between fluid and walls.
- They are important when modeling meniscus, capillary effects, and wettability.
- Can impose static equilibrium contact angle or dynamic contact angle at the walls.



Governing equations and interfacial momentum transfer models

Volume-of-Fluid (VOF) governing equations for separated systems

- Wall adhesion and contact angle:

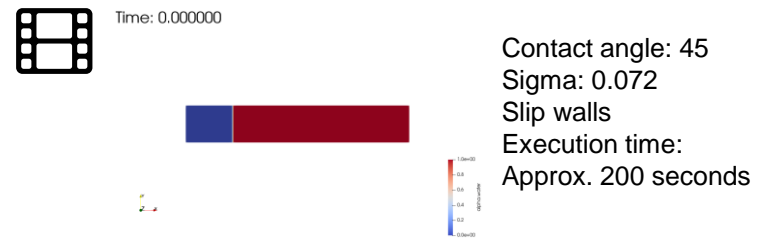
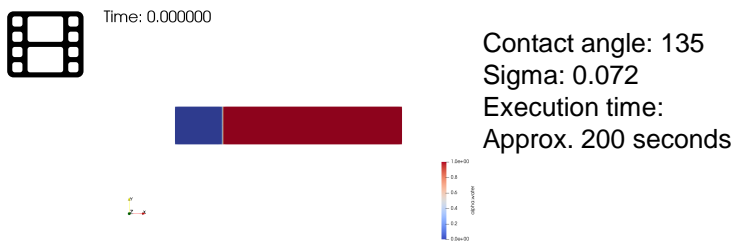
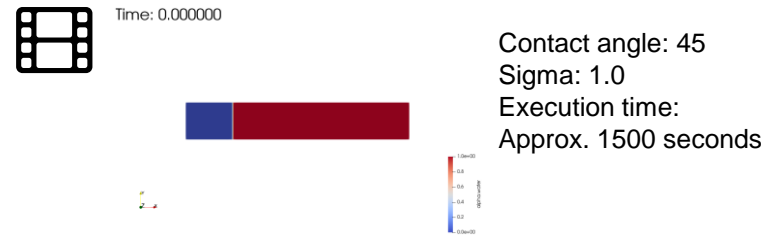
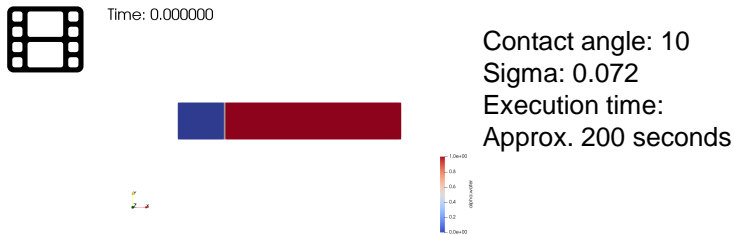
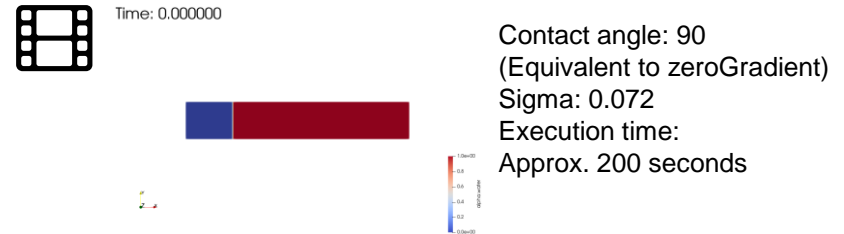
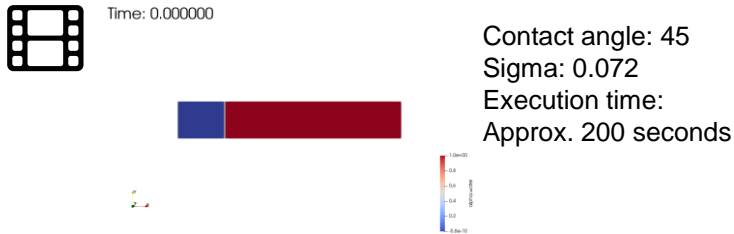

Governing equations and interfacial momentum transfer models

Volume-of-Fluid (VOF) governing equations for separated systems

- The best know applications of the VOF method are towing tank simulations and rigid body motion.
- These type of simulations are relatively easy.
- We will not deal with them; they are closely related to naval applications.
- However, we will give you the building blocks.
- Have in mind that when setting boundary and initial conditions for turbulent flows, it is recommended to use the primary phase properties to compute the turbulent quantities.

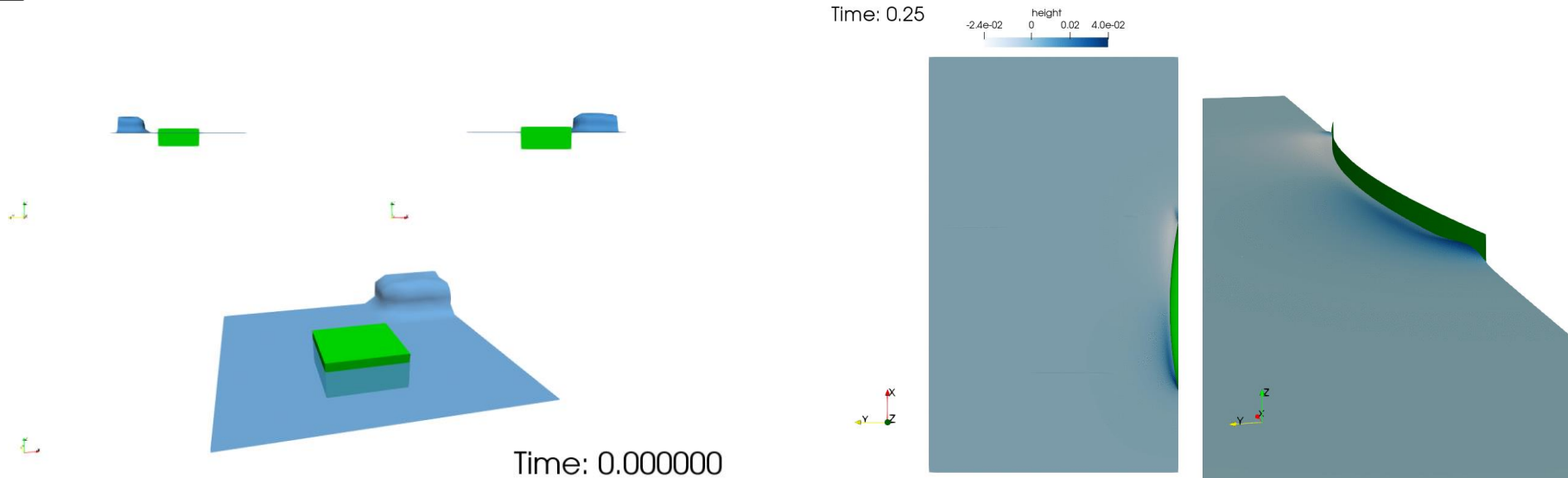

Governing equations and interfacial momentum transfer models

Volume-of-Fluid (VOF) governing equations for separated systems



Non-uniform cell size at the interface

Uniform cell size at the interface

- A very important requirement of towing tank applications (and similar applications), is that the mesh should be uniform at the mesh interface.
- A non-uniform interface will generate unphysical perturbations due to the change of cell size and cell center location at the interface.

Turbulence modeling corrections

- Turbulence kinetic energy can be over-predicted in VOF solvers at the phase interface.
- This well known deficiency of the turbulence models when dealing with multiphase flows can be corrected using multiphase stabilization techniques.
- The stabilization techniques usually will add an extra source term to the mixture or phase epsilon or omega equation to reduce turbulence generated near a free-surface.
- The interested reader can find a few implementations in the following references,
 - Devolder, B., Rauwoens, P., and Troch, P. (2017). Application of a buoyancy-modified k-w SST turbulence model to simulate wave run-up around a monopile subjected to regular waves using OpenFOAM. *Coastal Engineering*, 125, 81-94.
 - Larsen, B.E. and Fuhrman, D.R. (2018). On the over-production of turbulence beneath surface waves in Reynolds-averaged Navier-Stokes models *J. Fluid Mech*, 853, 419-460
 - Frederix, E. M. A., Mathur, A., Dovizio, D., Geurts, B. J., Komen, E. M. J. (2018). Reynolds-averaged modeling of turbulence damping near a large-scale interface in two-phase flow. *Nuclear engineering and design*, 333, 122-130.

Eulerian-Eulerian governing equations for dispersed systems

Time: 1.000000

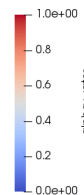

Time: 0.5

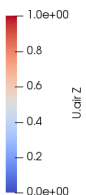

<http://www.wolfynamics.com/training/mphase/image17.gif>

<http://www.wolfynamics.com/training/mphase/image18.gif>

Governing equations and interfacial momentum transfer models

Eulerian-Eulerian governing equations for dispersed systems

- The Eulerian-Eulerian approach solves the governing equations for each phase, it treats the phases as interpenetrating continua.
- The incompressible, isothermal governing equations can be written as follows,

$$\frac{\partial \alpha_k \rho_k}{\partial t} + \nabla \cdot (\alpha_k \rho_k \mathbf{U}_k) = 0$$

$$\frac{\partial (\alpha_k \rho_k \mathbf{U}_k)}{\partial t} + \nabla \cdot (\alpha_k \rho_k \mathbf{U}_k \mathbf{U}_k) = -\nabla \cdot (\alpha_k \boldsymbol{\tau}_k) - \alpha_k \nabla p + \alpha_k \rho_k \mathbf{g} + \mathbf{M}_k + f_\sigma + \mathbf{S}_k$$

$$\sum_k \alpha_k = 1.0 \quad \rho_m = \sum_k \alpha_k \rho_k \quad \mathbf{U}_m = \frac{\sum_k \alpha_k \rho_k \mathbf{U}_k}{\rho_m}$$

Interface forces or
momentum transfer

Surface tension

- Source terms:
- Porous media
 - Coriolis forces
 - Centrifugal forces
 - Mass transfer
 - and so on ...

Governing equations and interfacial momentum transfer models

Eulerian-Eulerian governing equations for dispersed systems

- The incompressible, isothermal governing equations with interface tracking can be written as follows,

$$\frac{\partial \alpha_k \rho_k}{\partial t} + \nabla \cdot (\alpha_k \rho_k \mathbf{U}_k) = 0$$

$$\frac{\partial (\alpha_k \rho_k \mathbf{U}_k)}{\partial t} + \nabla \cdot (\alpha_k \rho_k \mathbf{U}_k \mathbf{U}_k) = -\nabla \cdot (\alpha_k \boldsymbol{\tau}_k) - \alpha_k \nabla p + \alpha_k \rho_k \mathbf{g} + \mathbf{M}_k + f_\sigma + \mathbf{S}_k$$

$$\frac{\partial \alpha_k \rho_k}{\partial t} + \nabla \cdot \mathbf{U}_k \alpha_k \rho_k + \nabla \cdot (\mathbf{U}_r \alpha_k \rho_k (1 - \alpha_k)) = 0$$

$$\sum_k \alpha_k = 1.0 \quad \rho_m = \sum_k \alpha_k \rho_k \quad \mathbf{U}_m = \frac{\sum_k \alpha_k \rho_k \mathbf{U}_k}{\rho_m}$$

Interface forces or
momentum transfer

Surface tension

Source terms:

- Porous media
- Coriolis forces
- Centrifugal forces
- Mass transfer
- and so on ...

Interfacial momentum transfer models

- Closure relations for the interface forces (models).
- Hereafter, we will describe the most common ones.

$$\mathbf{M}_l = -\mathbf{M}_g = \mathbf{M}_D + \mathbf{M}_L + \mathbf{M}_{VM} + \mathbf{M}_{TD}$$

Drag

$$\mathbf{M}_D = \frac{3}{4} \alpha_g \rho_l \frac{C_d}{d_b} |\mathbf{U}_l - \mathbf{U}_g| (\mathbf{U}_l - \mathbf{U}_g)$$

Lift

$$\mathbf{M}_L = \alpha_g \rho_l C_l (\mathbf{U}_l - \mathbf{U}_g) \times \nabla \times \mathbf{U}_l$$

Virtual Mass

$$\mathbf{M}_{VM} = \alpha_g \rho_l C_{VM} (\mathbf{U}_l \left(\frac{D_l \mathbf{U}_l}{D_t} - \frac{D_g \mathbf{U}_g}{D_t} \right))$$

Turbulence Dispersion

$$\mathbf{M}_{TD} = \rho_l C_{TD} \kappa \nabla \alpha_g$$

Interfacial momentum transfer models

- To deal with interfacial momentum transfer, there are many models in the multiphase literature.
- We are going to briefly address a few of models.
- We want to remind you that there is no universal model, it is up to you to choose the model that best fit the problem you are solving.
- Depending on the physics involved and the solver you are using, you will find different models and formulations
- You need to know the applicability and limitations of each model (refer to the literature).
- Most of the times, it is enough to use a drag force and virtual mass models.

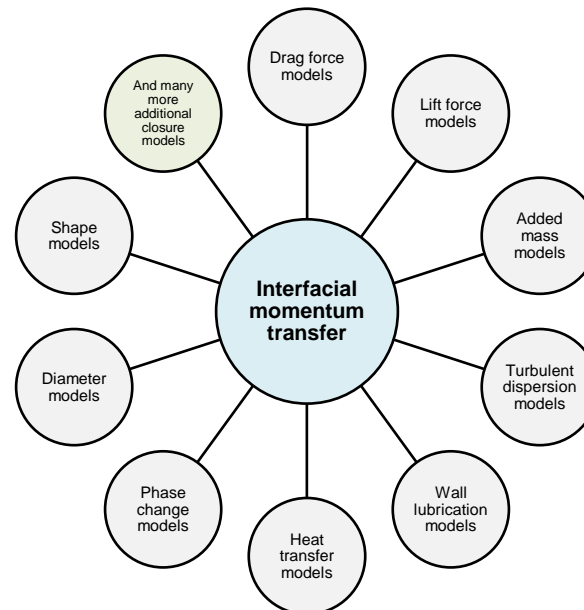

Interfacial momentum transfer models

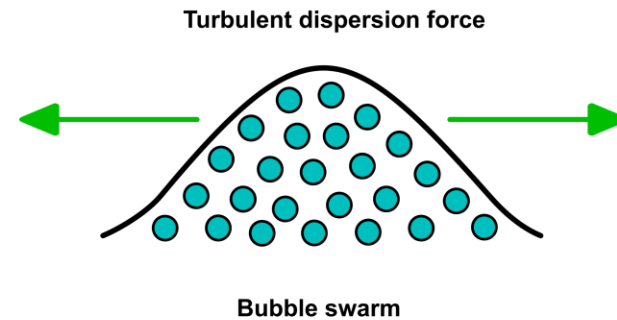
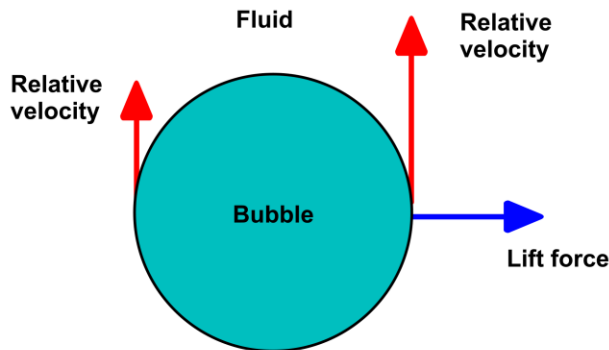
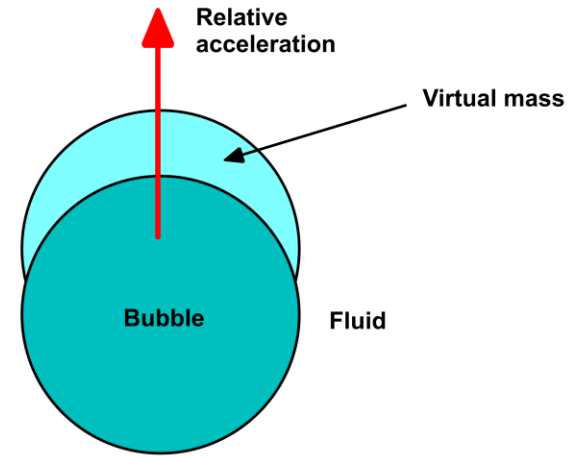
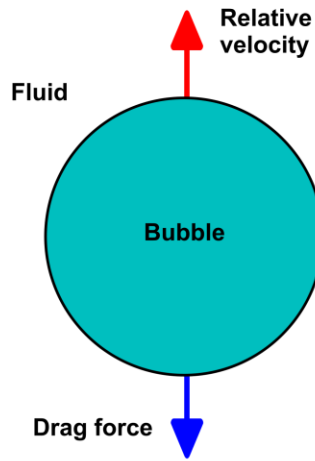

Interfacial momentum transfer models

- The drag force can be written as follows,

$$\mathbf{M}_D = \frac{3}{4} \alpha_g \rho_l \frac{C_d}{d_b} |\mathbf{U}_l - \mathbf{U}_g| (\mathbf{U}_l - \mathbf{U}_g)$$

- Using Schiller and Naumann model for C_d ,

$$C_d = \begin{cases} \frac{24}{Re} (1 + 0.15 Re^{0.687}) & Re \leq 1000 \\ 0.44 & Re > 1000 \end{cases}$$

$$Re = \frac{d_b |\mathbf{U}_l - \mathbf{U}_g|}{\nu_l}$$

When the Re is less than 10 most of the drag models reduce to Stokes law

- For small and constant bubble size this model work very well.

Interfacial momentum transfer models

Glycerol

Water

Gas superficial velocity
(mm/s)

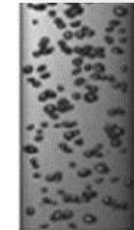
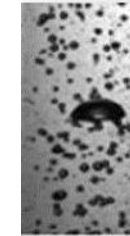

3

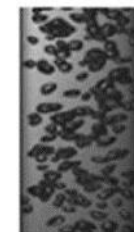
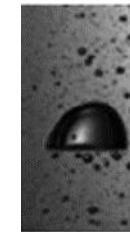

15

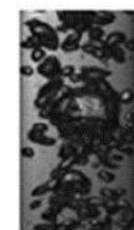
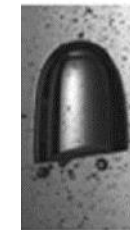

35



60

- Additional notes on drag models:

- For bubble columns operating at low gas superficial velocities (< 5 cm/s), drag models using mean bubble size approach work fine.
- For bubble columns operating at higher gas superficial velocities (> 5 cm/s), bubble breakup and coalesce dominate and bubble size is no longer uniform and mean bubble size approach may not be adequate.
- For gas superficial velocities higher than > 5 cm/s, it is recommended to use population balance models.
- When the bubble size is small (< 1 mm in water), bubble size is approximately spherical.
- When bubble size is large (> 18 mm in water), bubble is approximately a spherical cap.
- For intermediate bubble sizes, bubbles exhibit complex and random shapes.

Interfacial momentum transfer models

- The lift force can be written as follows,

$$\mathbf{M}_L = \alpha_g \rho_l C_l (\mathbf{U}_l - \mathbf{U}_g) \times \nabla \times \mathbf{U}_l$$

- Using Tomiyama model for C_l ,

$$C_l = \begin{cases} \min \begin{cases} 0.2888 \tanh(0.121 Re) & E_o < 4 \\ 0.00105 E_o^3 - 0.0159 E_o^2 - 0.0204 E_o + 0.474 & 4 \leq E_o \leq 10 \end{cases} \\ -0.29 & E_o > 10 \end{cases}$$

$$Re = \frac{d_b |\mathbf{U}_l - \mathbf{U}_g|}{\nu_l}$$

$$E_o = \frac{\Delta \rho g d_g^2}{\sigma}$$

Interfacial momentum transfer models

- Additional notes on lift models:
 - The lift force depends on the bubble diameter, the relative velocity between the phases, and the vorticity.

$$\mathbf{M}_L = \alpha_g \rho_l C_l (\mathbf{U}_l - \mathbf{U}_g) \times \nabla \times \mathbf{U}_l$$

- The lift coefficient is often constant for Reynolds number less than 500. If this is the case, it can be set to 0.5.
- Lift forces are responsible for inhomogeneous radial distribution of the dispersed phase.
- The Tomiyama model probably is the most general model. It is suitable for all shape and size of bubbles and drops.

Interfacial momentum transfer models

- The turbulence dispersion force can be written as follows,

$$\mathbf{M}_{TD} = \rho_l C_{TD} \kappa \nabla \alpha_g$$

- Using constant coefficient turbulence dispersion model C_{TD} ,

$$C_{TD} = 1$$

Interfacial momentum transfer models

- Additional notes on turbulence dispersion models:
 - The turbulence dispersion force accounts for an interaction between turbulent eddies and particles.
 - Results in a turbulent dispersion and homogenization of the dispersed phase distribution.
 - The simplest way to model turbulent dispersion is by assuming gradient transport as follows,

$$\mathbf{M}_{TD} = \rho_l C_{TD} \kappa \nabla \alpha_g$$

- Many models are available.
- For medium sized bubbles the Lopez model is a good choice.
- For small sized bubbles, the Burns model is recommended.

Interfacial momentum transfer models

- The virtual mass force can be written as follows,

$$\mathbf{M}_{VM} = \alpha_g \rho_l C_{VM} \mathbf{U}_l \left(\frac{D_l \mathbf{U}_l}{D_t} - \frac{D_g \mathbf{U}_g}{D_t} \right)$$

- Using constant coefficient virtual mass model C_{VM} ,

$$C_{VM} = 0.5$$

Some interfacial momentum transfer models

- Diameter models:
 - IATE
 - Constant
 - Isothermal
 - Linear
- These models are used to define the diameter of the bubbles or droplets.
- Most of the time is fine to use the constant diameter model.

Some interfacial momentum transfer models

- Aspect ratio models:
 - Tomiyama
 - Vakhrushev-Efremov
 - Wellek
 - Constant
- These models are used to define the aspect ratio of the bubbles or droplets.
- The constant model with Eo equal to 1.0 is equivalent to perfect spherical bubbles.

Some interfacial momentum transfer models

- Drag models:
 - Ergun
 - Gibilaro
 - Gidaspow-Ergun-WenYu
 - Gidaspow-Schiller-Naumann
 - Ishii-Zuber
 - Schiller-Naumann
 - Syamlal-OBrien
 - Tomiyama
 - Lain
 - WenYu
- These models are used to compute the drag forces on the bubbles or droplets.
- Most of the times is fine to use the Schiller and Naumann model.
- The Tomiyama model is a good alternative for deforming models.
- If the bubbles do not deform (they are rigid), the Syamlal model is the best option.

Some interfacial momentum transfer models

- Virtual mass models:
 - Lamb
 - Constant coefficient
- Virtual mass force represents the force due to inertia of the dispersed phase due to acceleration.
- Most of the times is fine to use the constant coefficient with a value of 0.5.

Some interfacial momentum transfer models

- Lift models:
 - Legendre-Magnaudet
 - Moraga
 - Tomiyama
 - Constant coefficient
- The lift force is mainly due to velocity gradients in the continuous phase. The lift force is equivalent to lateral forces.
- In most cases, the lift force is insignificant compared to the drag force, so there is no need to model this force.
- Tomiyama model is a good choice if you want to use a model.
- For low Reynolds number (less than 500) you can use a constant coefficient model with a value of 0.5.

Some interfacial momentum transfer models

- Wall lubrication models:
 - Antal
 - Frank
 - Tomiyama
- Wall lubrication models take into account the repulsive effect, which bubbles are exerted to in the vicinity of the wall of the column as a consequence of an asymmetric incident flow near the wall boundary layer.
- Most of the times it is not needed to model this force.

Some interfacial momentum transfer models

- Turbulent dispersion models:
 - Burns
 - Gosman
 - LopezDeBertodano
 - Constant coefficient

- The turbulent dispersion models account for the interaction between turbulent eddies and particles.
- Most of the times it is not needed to model this force.
- Burns model with a constant coefficient equal to 1.0 is a good choice if you want to use a model.

Some interfacial momentum transfer models

- Heat transfer models:
 - Constant Nu
 - Gunn
 - Ranz-Marshall
 - Spherical heat transfer
- These models are used to compute the heat transfer from idealized geometries.

Eulerian-Eulerian governing equations for dispersed systems of gas-solid or liquid-solid (Eulerian-Granular KTGF)

Time: 0.000000

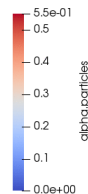

Time: 0.00

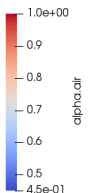

Governing equations and interfacial momentum transfer models

Eulerian-Eulerian governing equations for dispersed systems of gas-solid or liquid-solid (Eulerian-Granular KTGF)

- The Eulerian-Granular KTGF (kinetic theory of granular flow), is based on the kinetic theory of granular flow (analogous to kinetic theory of gases).
- In the E-G KTGF the liquid phase is solved as in the Eulerian-Eulerian method and the solid phase is solved using appropriate closure relations.
- The incompressible, isothermal governing equations can be written as follows,

$$\frac{\partial \alpha_k \rho_k}{\partial t} + \nabla \cdot (\alpha_k \rho_k \mathbf{U}_k) = 0$$

$$\frac{\partial (\alpha_k \rho_k \mathbf{U}_k)}{\partial t} + \nabla \cdot (\alpha_k \rho_k \mathbf{U}_k \mathbf{U}_k) = -\nabla \cdot (\alpha_k \boldsymbol{\tau}_k) - \alpha_k \nabla p - \gamma_k \nabla p_k + \alpha_k \rho_k \mathbf{g} + \mathbf{M}_k$$

$\gamma_k = \frac{\alpha_{s,k}}{\sum_k \alpha_{s,k}}$

Stress tensor for solid and fluid Shared pressure Disperse phase pressure Momentum transfer

Governing equations and interfacial momentum transfer models

Eulerian-Eulerian governing equations for dispersed systems of gas-solid or liquid-solid (Eulerian-Granular KTGF)

- With the following closure relations (transport equation of granular temperature or velocity fluctuations).

$$\frac{3}{2} \left[\frac{\partial \alpha_s \rho_s \Theta_s}{\partial t} + \nabla \cdot (\alpha_s \rho_s \Theta_s \mathbf{U}_s) \right] = (-\nabla p_s \mathbf{I} + \tau_s) : \nabla \mathbf{U}_s + \nabla \cdot (k_s \nabla \Theta_s) - \gamma_s + J_s$$

- Granular temperature

$$\Theta_s = \frac{1}{3} \mathbf{U}_{fs}^2 \longrightarrow \text{Particle fluctuating velocity}$$

- Solid stress tensor

$$\tau_s = -p_s \mathbf{I} + 2\alpha_s \mu_s \frac{1}{2} (\nabla \mathbf{U}_s + \nabla \mathbf{U}_s^T) + \alpha_s (\lambda_s - \frac{2}{3} \mu_s) \nabla \cdot \mathbf{U}_s \mathbf{I}$$

- Equation of state for the dispersed phase

$$p_s = \rho_s \alpha_s \Theta_s + 2\rho_s \alpha_s^2 g_0 \Theta_s (1 + e_s)$$

Governing equations and interfacial momentum transfer models

Eulerian-Eulerian governing equations for dispersed systems of gas-solid or liquid-solid (Eulerian-Granular KTGF)

- Plus, the following additional terms that require closure relations (models),

λ_s Solid bulk viscosity

μ_s Solid shear viscosity

τ_f Frictional stresses

g_0 Radial distribution function

κ Conductivity of granular energy

e_s Coefficient of restitution of colliding particles

γ_s Dissipation of granular energy

J_s Exchange of fluctuating energy between the phases

\mathbf{M}_k Momentum transfer models (usually only drag for gas-solid)

For a complete derivation of the governing equation and closure relations, refer to:

Derivation, Implementation, and Validation of Computer Simulation Models for Gas-Solid Fluidized Bed

B. van Wachem. PhD Thesis. 2000, TUDelft.

Governing equations and interfacial momentum transfer models

Eulerian-Eulerian governing equations for dispersed systems of gas-solid or liquid-solid (Eulerian-Granular KTGF)

- In the transport equation of granular temperature

$$\frac{3}{2} \left[\frac{\partial \alpha_s \rho_s \Theta_s}{\partial t} + \nabla \cdot (\alpha_s \rho_s \Theta_s \mathbf{U}_s) \right] = (-\nabla p_s \mathbf{I} + \tau_s) : \nabla \mathbf{U}_s + \nabla \cdot (k_s \nabla \Theta_s) - \gamma_s + J_s$$

- The first term on the RHS represents the creation of fluctuating energy due to shear in the particle phase.
- The second term on the RHS represents the diffusion of fluctuating energy along gradients in the Θ_s .
- γ_s represents the dissipation due to inelastic particle-particle collisions.
- J_s represents the dissipation or creation of granular energy resulting from the working of the fluctuating force exerted by the gas through the fluctuating velocity of the particles.

Some interfacial momentum transfer models

- Conductivity models :
 - Gidaspow
 - Hrenya-Sinclair
 - Syamlal

- Frictional stress models:
 - Johnson-Jackson
 - Johnson-Jackson-Schaeffer
 - Schaeffer

Note: there is a Johnson and Jackson boundary condition for walls

- Granular pressure models:
 - Lun
 - Syamlal-Rogers-OBrien

Some interfacial momentum transfer models

- Radial distribution function models:
 - Carnahan-Starling
 - Lun-Savage
 - Sinclair-Jackson
- Viscosity models:
 - Gidaspow
 - Hrenya-Sinclair
 - Syamlal

Eulerian-Lagrangian governing equations

Time: 0.002000

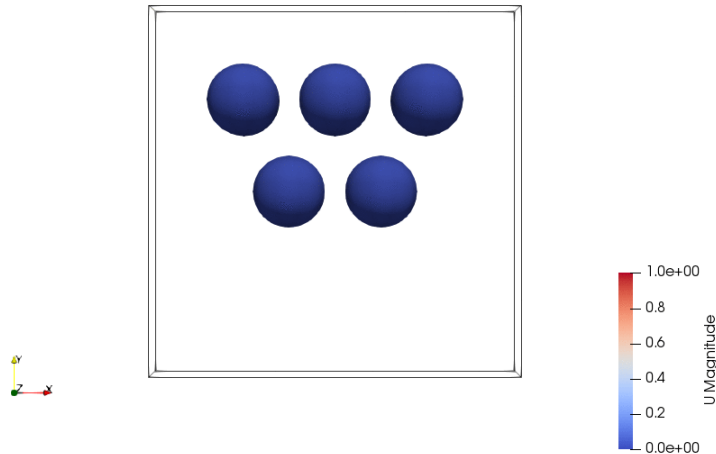

<http://www.wolfynamics.com/training/mphase/image21.gif>

U_{air} Magnitude
0.0e+00 10 2.4e+01

U_{Particle} Magnitude
0.0e+00 5 10 1.5e+01

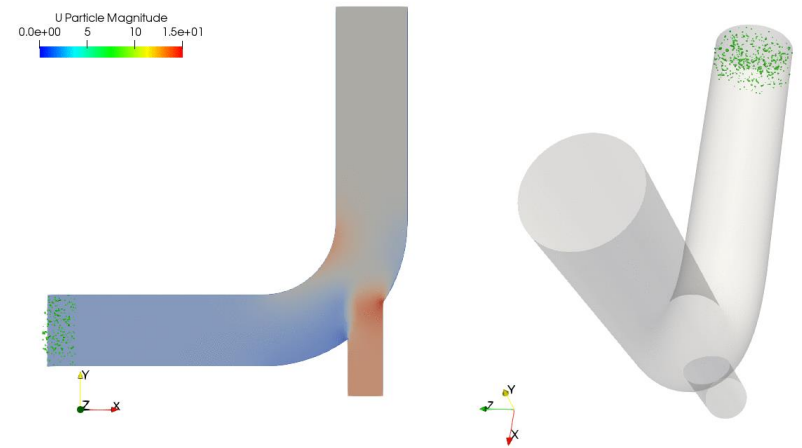

Time: 0.05

<http://www.wolfynamics.com/training/mphase/image22.gif>

Some Eulerian-Lagrangian models

- In the Eulerian-Lagrangian framework, the continuous phase is solved in a Eulerian reference system and the particles or dispersed phase is solved in a Lagrangian reference system.
- The governing equations can be written as follows,

$$m \frac{d\mathbf{U}}{dt} = \mathbf{F}_{drag} + \mathbf{F}_{pressure} + \mathbf{F}_{virtual\ mass} + \mathbf{F}_{other}$$

+

Any of the Eulerian formulations (single or multi-phase)

Some Eulerian-Lagrangian models

- In this formulation the secondary phase is treated as discrete particles dispersed in the continuous fluid.
- The particles can be smaller or larger than the grid size.
- The particles can be transported passively, or they can be coupled with the fluid governing equations. That is, the particles can modify the fluid field.
- This formulation accounts for particle interaction and mass transfer.
- The particles can interact with the boundaries and have a fate. They can escape, bounce, stick, or form a wall film.
- If you want, you can add angular momentum to the formulation.
- Depending on the number of particles tracked, this type of approach can be computationally expensive.

Some Eulerian-Lagrangian models

- Generally speaking, There are two approaches to model Eulerian-Lagrangian systems with hydrodynamic coupling.
- The DPM or Dense Particle Flows approach, which includes the effect of the particulate volume fraction on the continuous phase, suitable for dense particle flow simulation.
- The MPPIC or Multiphase Particle-in-Cell method* for collisional exchange. In this approach, particle-particle interactions are represented by models which utilize mean values calculated on the Eulerian mesh.
- The MPPIC is suitable for dense to dilute regimes.

Some Eulerian-Lagrangian models

$$m \frac{d\mathbf{U}}{dt} = \mathbf{F}_{drag} + \mathbf{F}_{pressure} + \mathbf{F}_{virtual\ mass} + \mathbf{F}_{other}$$

+

$$\nabla \cdot \mathbf{U} = 0$$

$$\frac{\partial \rho \mathbf{U}}{\partial t} + \nabla \cdot (\rho \mathbf{U} \mathbf{U}) = -\nabla p + \nabla \cdot \boldsymbol{\tau} + \rho \mathbf{g} + \rho \mathbf{S}$$

Some Eulerian-Lagrangian models

$$m \frac{d\mathbf{U}}{dt} = \mathbf{F}_{drag} + \mathbf{F}_{pressure} + \mathbf{F}_{virtual\ mass} + \mathbf{F}_{other}$$

+

$$\nabla \cdot \mathbf{U} = 0$$

$$\frac{\partial \rho \mathbf{U}}{\partial t} + \nabla \cdot (\rho \mathbf{U} \mathbf{U}) = -\nabla p + \nabla \cdot \boldsymbol{\tau} + \rho \mathbf{g} + f_{\sigma} + \rho \mathbf{S}$$

$$\frac{\partial \gamma}{\partial t} + \nabla \cdot \mathbf{U} \gamma + \nabla \cdot (\mathbf{U}_r \gamma (1 - \gamma)) = 0$$

Some Eulerian-Lagrangian models

$$m \frac{d\mathbf{U}}{dt} = \mathbf{F}_{drag} + \mathbf{F}_{pressure} + \mathbf{F}_{virtual\ mass} + \mathbf{F}_{other}$$
$$+$$

$$\frac{\partial \alpha_k \rho_k}{\partial t} + \nabla \cdot (\alpha_k \rho_k \mathbf{U}_k) = 0$$

$$\frac{\partial (\alpha_k \rho_k \mathbf{U}_k)}{\partial t} + \nabla \cdot (\alpha_k \rho_k \mathbf{U}_k \mathbf{U}_k) = -\nabla \cdot (\alpha_k \boldsymbol{\tau}_k) - \alpha_k \nabla p + \alpha_k \rho_k \mathbf{g} + \mathbf{M}_k + f_\sigma + \mathbf{S}_k$$

$$\frac{\partial \alpha_k \rho_k}{\partial t} + \nabla \cdot \mathbf{U}_k \alpha_k \rho_k + \nabla \cdot (\mathbf{U}_r \alpha_k \rho_k (1 - \alpha_k)) = 0$$

Some Eulerian-Lagrangian models

- Dispersion models:
 - Gradient Dispersion RANS
 - Stochastic Dispersion RANS

- Particle injection models:
 - Zone injection
 - Cone injection
 - Table injection
 - Manual injection
 - Patch flow rate injection
 - Patch injection

Some Eulerian-Lagrangian models

- Particle force models:
 - Drag
 - Gravity
 - Lift
 - Paramagnetic
 - Pressure Gradient
 - Virtual mass
 - Brownian motion
- Patch (wall) interaction models:
 - Local interaction
 - No interaction
 - Patch interaction model
 - Rebound
 - Standard wall interaction

Some Eulerian-Lagrangian models

- Patch interaction type (particles fate):
 - Rebound
 - Stick
 - Escape
 - React

- Particle distribution models:
 - Exponential
 - Fixed value
 - Rosin-Rammler
 - Normal iddistribution
 - Uniform distribution

Some Eulerian-Lagrangian models

- And the list keep going up if you add mass transfer, chemical species, combustion, reactions, compressibility effects, and so on.
- All these models depend on the turbulence models

Final remarks

- In all the previous formulations we wrote the governing equations in their laminar form.
- To add turbulence, you only need to do the proper averaging (Reynolds or Favre) or use a filtering technique for LES simulations.
- In the Eulerian-Eulerian formulation for dispersed systems, the stress term in the new equations will become:

$$\tau_k = -\mu_{eff,k}(\nabla \mathbf{U}_k + \nabla \mathbf{U}_k^T - \frac{2}{3} \mathbf{I}(\nabla \cdot \mathbf{U}_k))$$

- You will need to use the proper closure relation for finding $\mu_{eff,k}$
- In the Eulerian-Eulerian formulation for separated systems (VOF), only one phasic set of closure relations for turbulence models are solved (the Reynolds or Leonard stress tensor is the same as for single-phase flows).

Final remarks

- In all the previous formulations we wrote the incompressible, isothermal governing equations.
- You can add the energy equation, which is written as follows

$$\frac{\partial \rho c_p T}{\partial t} + \nabla \cdot (\rho c_p \mathbf{U} T) = -\nabla \cdot \mathbf{q} + \tau : \nabla \mathbf{U} + S$$

- By adding the energy equation, you can model mass transfer between phases.
- By adding thermal effects, you can model boiling, melting, freezing, sublimation, condensation, evaporation.
- You can also model cavitation and flashing. Have in mind that they are driven by local pressure effects.

Final remarks

Eulerian-Eulerian (VOF)	Eulerian-Eulerian (Dispersed systems)	Eulerian-Lagrangian
<ul style="list-style-type: none">• Non-interpenetrating continua.• Continuous phases: Eulerian.• Fluid properties are written on either side of the interface (no averaging).• Solves one single set of PDEs: mass, momentum, energy.	<ul style="list-style-type: none">• Interpenetrating continua.• Continuous phase: Eulerian.• Dispersed phase: Eulerian.• Phase-weighted averages.• Solves PDEs for all phases (including interphase transfer terms): mass, momentum, energy.	<ul style="list-style-type: none">• Continuous phase: Eulerian.• Dispersed phase: Lagrangian.• Solves ODEs for particle tracking (for every single particle).• Solves a set of PDEs for the continuous phase: mass, momentum, energy.• Phase interaction terms (including interphase transfer terms).

Final remarks

Eulerian-Lagrangian approach advantages

- Complete and detailed information about behavior and residence time of individual particles.
- Relative cheaper than the Eulerian-Eulerian approach for a wide range of particle sizes.
- Better detail for drag, heat and mass transfer.

Eulerian-Lagrangian approach drawbacks

- For large volume fractions the model is not very accurate.
- Can be very expensive if it is necessary to track a large number of particles
- Difficult to get smooth information about local values of volume fractions, velocities, forces on walls, and so on.